

Table of Contents

General guidelines	2
Regulations and safety requirements.....	3
Valve introduction	4
Valve installation.....	5
Valve removal.....	6
Valve disassembly and inspection.....	6-12
Valve reassembly and requalification.....	13-18
Routine maintenance.....	18
Operation	18
Emergency response for leaking valve.....	18

General Guidelines

- The owner must comply exclusively with these operating instructions and the authorized use of this piece of equipment. Should problems arise that cannot be solved using these operating instructions, please contact Dixon®. We will be happy to provide further assistance.
- If any modification work is performed on the product by the owner, Dixon shall no longer be considered the manufacturer of the device. In such cases, all components must be subjected to a new certification process for any applicable certifications that the equipment holds. Unless agreed to in writing by Dixon, liability, warranties, and guarantees shall immediately be deemed null and void as soon as the owner:
 - Performs modifications/conversion work on the product.
 - Uses the product for unauthorized purposes.
 - Removes or disable safety elements.
 - Processes products whose material, form, and size do not correspond exactly to the description provided.
 - Makes alterations to the original state of the device.
- The operating instructions are regarded as part of the product.
- The operating and maintenance personnel must always be able to access the operating instructions.
- The safety instructions provided in the operating instructions must be observed.
- The operating instructions shall be valid for the entirety of the device's lifespan.
- The operating instructions must be maintained and updated as necessary.
- The operating instructions must be passed on to any subsequent owners or operators of the device.

Safety Information

The following signs may be used in this manual. To avoid serious injury and/or possible damage to equipment, pay attention to these messages. Hazards or unsafe practices could result in severe personal injury or death.



DANGER Indicates a hazardous situation that, if not avoided, will result in death or serious injury.



WARNING Indicates a hazardous situation that, if not avoided, could result in death or serious injury.



CAUTION Indicates a hazardous situation that, if not avoided, could result in minor or moderate injury.

Use only replacement parts and devices recommended by the manufacturer to maintain the integrity of the equipment. Make sure the parts are correctly matched to the series, model, serial number, and revision level of the equipment.

Safety labels are placed on equipment where appropriate. Do not remove any labeling from any piece of equipment. Replace any label that is missing.

DO NOT modify any Dixon product. Non-factory modifications could create hazardous conditions and void all warranties. DO NOT attempt to use a Dixon product in any application that exceeds the product rating.

Regulations and Safety Requirements

Regulations: Dixon® 2" angle valves are used in contact with a variety of products, many of which are hazardous materials and could cause serious injury or damage if mishandled. The acceptance and transportation of products are regulated by the DOT and the Association of American Railroads (AAR) in the U.S., and in Canada by CTC and Transport Canada. Regulations of other governmental bodies must be complied with for stationary and mobile applications. All personnel should be familiar with and follow these regulations. Nothing in these instructions is intended to conflict with or supersede these regulations. The information in this document was gathered from knowledgeable sources. However, Dixon makes no representations or guarantees about its accuracy or completeness and assumes no liability for this information.

Specifications are subject to change without notice.

This valve should only be installed, operated, and maintained by qualified personnel. Read these instructions carefully before proceeding. Operation of the valve must conform to all applicable specifications from TC, AAR, DOT, CFR (Parts 173.31, 174.67, etc.), and other governmental bodies, along with the operating instructions of your company.

Safety Precautions

Safety Warnings and Precautions: Please carefully read each of the following warnings and cautions prior to performing any work.



WARNING: Toxic Hazard: Always use extreme caution and proper equipment when involved with hazardous materials. To avoid exposure to toxic or hazardous materials, make sure the tank car is empty and clean and that the work area is free of hazardous chemicals before removing or installing any valve.

- Wear protective clothing and equipment suitable for withstanding the materials to which you may be exposed.
- Position yourself on the upwind side of the valve when possible.
- Work in a well-ventilated area.
- Work with a partner who can help you in the event of an emergency.
- Follow approved safety precautions for hazardous or toxic materials.
- Obtain SDS sheets for all the commodities used with the associated valve.



WARNING: When removing the angle valve from the tank car or performing maintenance, make sure the valve is in the open position. If the valve is seated and the plug is installed, hazardous commodity can be trapped inside the valve. If a fully closed valve with the plug installed is encountered, follow your company's guidelines on handling potentially hazardous material.

Valve Introduction

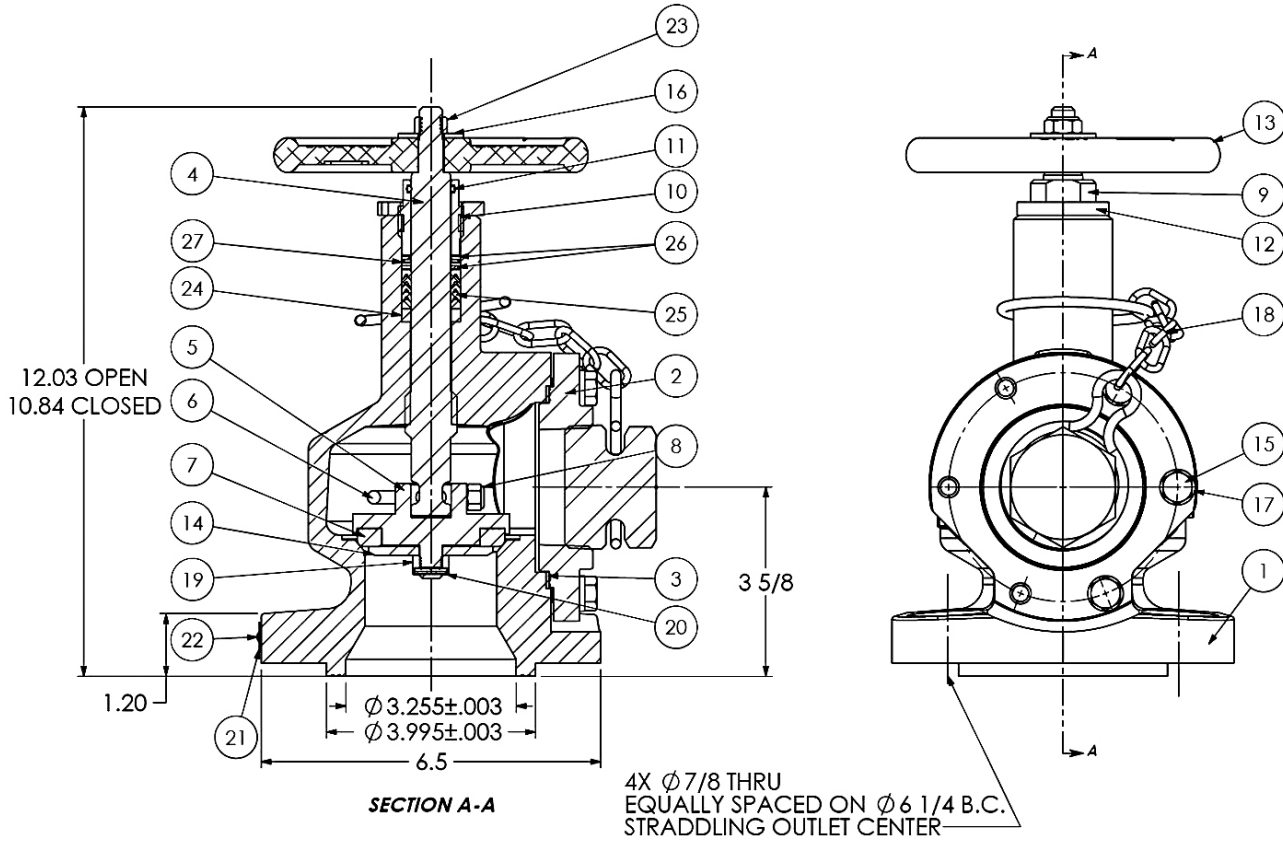

Item	Part #	Description	Material	Qty
1	180018-200-DI	body	ductile iron	1
2	180019-200-CS	outlet flange	carbon steel	1
3	180029-200-GL	outlet flange gasket	GYLON® 3510	1
4	180022-200-S4	stem	304 stainless steel	1
5	180021-200-CS	retainer	carbon steel	1
6	180028-200-S4	u-bolt	304 stainless steel	1
7	180027-200-PG	valve seat seal	glass filled PTFE	1
8	180041-200-S6	hex lock nut	316 stainless steel	2
9	180024-200-CS	packing screw	carbon steel	1
10	180098-100-PF	ptfe insert	PTFE	2
11	180044-200-FP	stem O-ring	FEP	1
12	180026-200-CS	packing lock nut	carbon steel	1
13	180020-200-ALX	handwheel	aluminum	1
14	180043-200-S4	seal retaining washer	304 stainless steel	1
15	F23816125Z29G5	hex head bolt	plated steel	6
16	180042-200-CS	washer	plated steel	1
17	W33800000Z29G5	split lock washer	plated steel	6
18	280010-200-CS	plug/chain assembly	plated steel	1
19	180039-200-CS	castle nut	plated steel	1
20	S21300063X0304	spring pin	18-8 stainless steel	1
21	180034	nameplate	304 stainless steel	1
22	180138	drive screw	304 stainless steel	2
23	180030-200-CS	nylon-insert locknut	plated steel	1
24	180172-200-S4	spacer	304 stainless steel	1
25	180094-100-PG	packing set	glass filled PTFE	1
26	180173-200-S4	washer	stainless steel (304)	2
27	180174-200-S7	wave spring	17-7PH stainless steel	1

NOTE: Alternate materials of construction are available.

Valve Installation

New valves are assembled, tested, and sealed at Dixon® prior to shipment.

Installation Procedure and Recommended Tools

Tool	Component
1-1/4" SAE wrench	mounting stud nuts
1-1/4" crowfoot	mounting stud nuts
torque wrench	mounting stud nuts and packing bushing
lint free cloth	for cleaning valve and cover plate sealing surfaces
Scotch-Brite®	for cleaning valve and cover plate sealing surfaces
wire brush	for cleaning mounting studs

Inspect the mounting stud threads and ensure there is no damage. Inspect the cover plate and tongue-and-groove sealing surface to ensure there are no dents or peened surfaces.

For tongue-and-groove installations:

- Inspect the groove in the cover plate. The fitment with the tongue on the valve should be very tight. Any peening of the tongue or groove edges could interfere with the proper installation of the valve. If there is damage to the groove, make any necessary corrections to meet the tolerances specified by the AAR.
- Inspect the tongue of the valve (new or reconditioned) by running your fingernail around both the inner and outer edges checking for damages. The tolerances on the tongue are +/- .003" so any excess material due to peening could cause the valve to not seat in the groove of the cover plate. Remove any excess material to meet the tolerances specified by the AAR.
- Install the new gasket into the groove. Ensure the gasket is seated evenly. There should be 1/16" of space above the gasket to allow the valve tongue to locate properly in the groove.



CAUTION: Groove Damage:

- Do not use a sharp tool to seat the gasket as damage may result.
- Verify that the valve tongue fits into the cover plate groove. Improper fit up could result in a leak and possible valve damage.

For flat-faced flange installations:

- Ensure the underside of the valve flange and the mating area on the cover plate are defect-free and clean.

Install the mounting studs into the cover plate following your company's procedure and requirements.

Mount the nuts onto the mounting studs and tighten in 1/3 torque increments using the pattern shown below. For recommended torque values contact your gasket manufacturer.

To complete this installation process, the tank car will need to be pressurized in accordance with the tank car owner's requirements. A bubble leak test must be performed per car owner's specifications.



WARNING: Valve Leakage: Improper valve-tongue seating in the flange groove, loose nuts and damaged gaskets may result in leaks at the valve-mounting joint.

Test all newly installed valves to conform with tank car owner specifications. No leaks should be present. Improper valve tongue seating in the groove, damaged gaskets, or loose mounting nuts may result in leaks at the cover plate mounting joint.

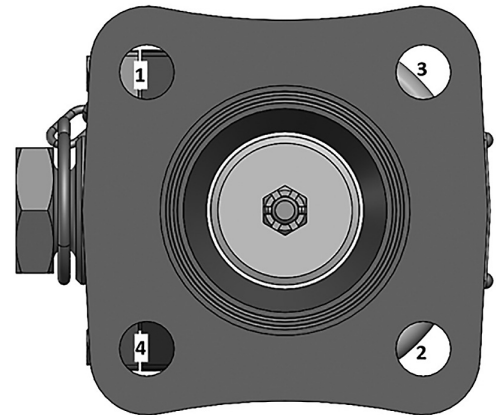

Valve Removal

Removal Procedure and Recommended Tools

Tool	Component
1-1/4" SAE wrench	mounting stud nuts
lint free cloth	for cleaning valve and cover plate sealing surfaces
Scotch-Brite®	for cleaning valve and cover plate sealing surfaces
wire brush	for cleaning mounting studs

1. Remove the valve by following your company's procedure for removal and securing the opening in the cover plate.
2. Using a wire brush, clean the threads of the mounting studs removing any rust or scale. The mounting nuts should move freely on the studs. Inspect the threads for any excessive wear, corrosion, or pitting. If any are found, the parts are rejectable and should be replaced.
3. Remove and dispose of any old mounting gasket material. Use care to ensure the mounting groove is not scratched or damaged.
4. Using a lint free cloth and an appropriate solvent, clean the mounting studs as well as the sealing surfaces on the valve and cover plate.

Valve Disassembly and Inspection

During disassembly of the valve, key components of the valve must be thoroughly inspected to ensure a properly operating valve after reassembly. These components include the handwheel, stem, seal retainer, body, plug, outlet flange, and valve body. Inspection includes looking for cracks, excessive wear, and other potential issues as described in more detail in the steps that follow.

Per the requirements by the AAR, all inspection and testing of pressure angle valves must follow the procedures developed by an ANST Level III Technician and be performed by a Non-Destructive Testing (NDT) qualified operator. See AAR M-1002 Appendix D "Retest and Qualification Requirements" and Appendix T "Nondestructive Examination". Additionally, all maintenance activity for this valve must be performed by an AAR M-1003 certified repair facility.

NOTICE: Machining is not allowed without consent from Dixon or the car owner. Machining, grinding, welding, or other alterations to the valve seat or stem is not allowed per AAR M-1002, Paragraph A3.11.1 of the tank car specifications.

NOTICE: Repair work is limited to cleaning and polishing without consent from Dixon® or the car owner. See AAR M-1002, Paragraph A3.11.1 of the tank car specifications.

Valve Disassembly and Recommended Tools

Tool	Component(s)/Description	Item #
9/16" SAE socket	hex bolts	15
deep 7/16" SAE socket or nut driver	hex lock nut on u-bolt	8
2" SAE wrench, socket or large adjustable wrench	plug	18
1-1/16" SAE wrench	packing screw	9
1-3/4" SAE wrench	packing lock nut	12
5/8" SAE socket or wrench	handwheel lock nut	23
punch and hammer	spring pin	20
11/16" SAE socket or wrench	disc retainer castle nut	19
non-scratching tool to remove O-rings	O-rings	11

1.

Using a 2" wrench or socket, remove the plug (item 18) from the outlet flange (item 2).

Using a wire brush, clean the threads of the outlet flange plug (item 2) removing any rust or scale. The outlet flange plug should move freely into and out of the valve. Inspect the threads for any excessive wear, corrosion, or pitting. If any are found, the plug is rejectable and should be replaced.

Using a lint free cloth and an appropriate solvent, clean the outlet flange plug.

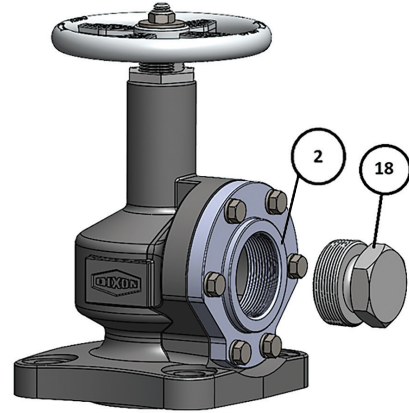

2.

Using a 9/16" socket, remove hex bolts (items 15) and split lock washers (items 17) from the outlet flange.

All hex bolts (item 15) split lock washers (item 17) should be replaced.

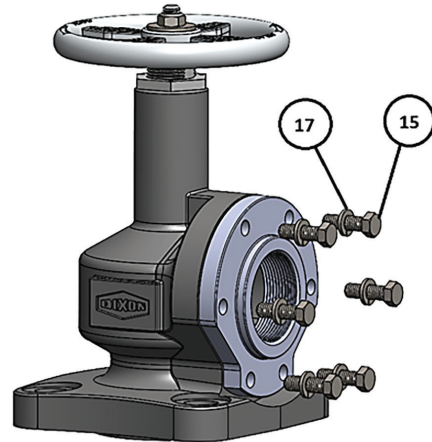

3.

Remove the outlet flange (item 2) and outlet flange gasket (item 3) from the body.

Clean the back surface sealing area of the outlet flange (item 2) and the mating valve surface. Use a lint free cloth and an appropriate solvent for final cleaning. Inspect the sealing areas for corrosion and pitting. If any are found, the parts are rejectable and should be replaced.

Remove and dispose of the gasket.

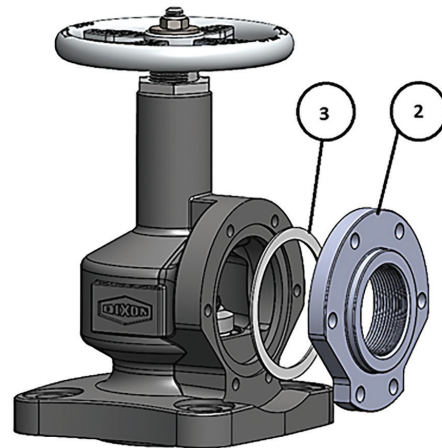

4.

Using the handwheel (item 13), close the valve until the seal retainer (item 5) bottoms out on the bottom of the body cavity. Make sure the hex lock nuts (items 8) are facing the side outlet of the valve.

Using a 7/16" socket or nut driver, remove the two hex lock nuts (items 8).

Use the handwheel (item 13) to open the valve slightly to rotate the seal retainer (item 5), to take out the u-bolt (item 6). A pair of needle nose pliers may be useful in removing the u-bolt.

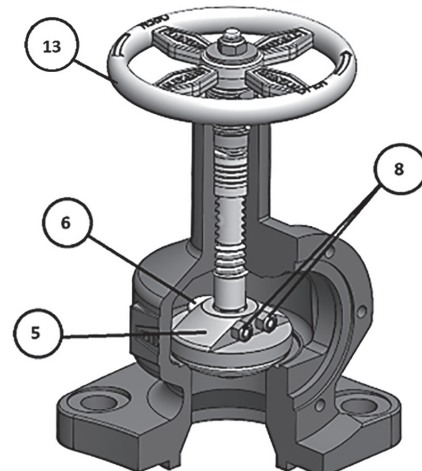

5.

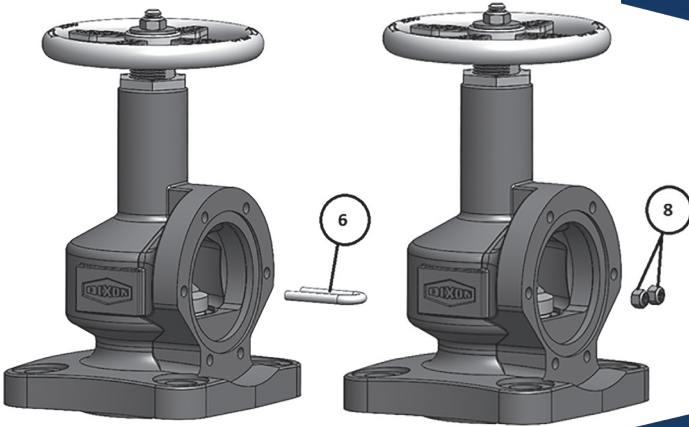

If necessary, use a wire brush to clean the threads of the u-bolt (item 6) and hex lock nuts (item 8) to remove any rust or scale. Inspect the threads for any excessive wear, corrosion, or pitting. If any are found, the components should be replaced.

Use a lint free cloth and an appropriate solvent for final cleaning of the u-bolt and hex lock nuts.

6.

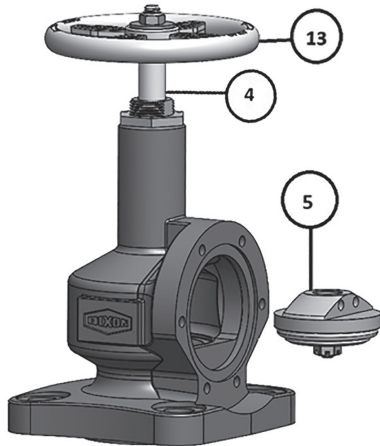

Using the handwheel (item 13), fully open the valve until the stem (item 4) runs out of upward travel.

Remove the seal retainer (item 5) from inside the body.

7.

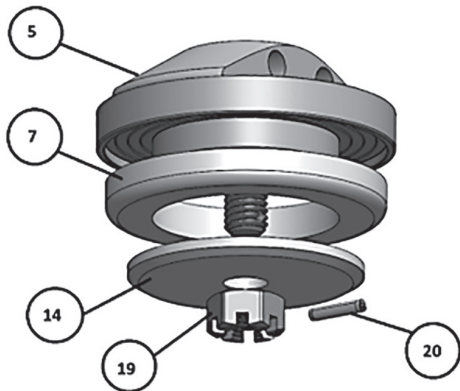

Place the seal retainer (item 5) in a vise holding on the flats. Utilizing a hammer and a punch remove the spring pin (item 20).

Using an 11/16" socket, unthread the disc retainer castle nut (item 19) and remove the retainer washer (item 14) and the seat seal (item 7).

If necessary, use a wire brush to clean the threads of the seal retainer (item 5) and the disc castle nut (item 19) to remove any rust or scale. Inspect the threads for any excessive wear, corrosion, or pitting. If any are found, the components should be replaced.

8.

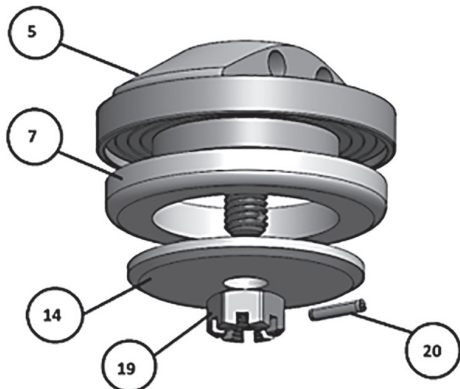

Check the sealing area (behind the seat seal (item 7)) of the seal retainer (item 5) for any excessive corrosion or pitting. If any are found, the seal retainer (item 5) should be replaced. Use care to ensure the sealing area is not scratched or damaged.

Replace the seat seal (item 7).

Clean and inspect the seal retaining washer (item 14) for any excessive corrosion, pitting and warpage. If any are found, the washer should be replaced.

Use a lint free cloth and an appropriate solvent for final cleaning of all components.

9.

Using a 5/8" socket, remove the lock nut (item 23) and washer (item 16). Then remove the handwheel (item 13). Inspect the handwheel for damage. The handwheel is designed to fail when the stem is over-torqued. If the metal around the square bore is cracked or broken off, replace the handwheel.

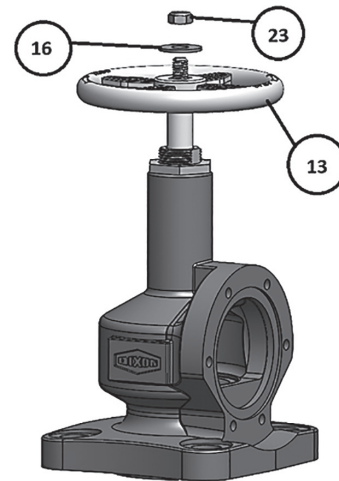

10.

Using a 1-3/4" SAE wrench remove the packing screw locknut (item 12). Then using a 1-1/16" SAE wrench on the flats, remove the packing screw (item 9).

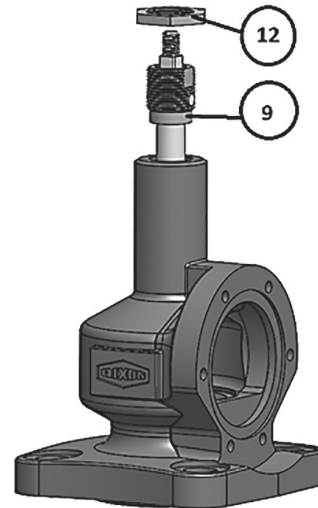

11.

Carefully remove the stem (item 4) from the valve body by turning counterclockwise slowly. The whole packing set will come out with the stem.

Separate the washers (items 26), wave spring (item 27), packing set (item 25), and spacer (item 24) from the stem. Inspect the stem (item 4) for damage. Roll the stem on a flat surface. If the stem is bowed, it needs to be replaced. If any cracks are present, scrap the stem and replace.

Inspect the packing area on the stem. If minor scratches are present, polish the stem smooth. If scratches persist or if there are any nicks, burrs, or pits on the packing area, discard the stem.

Inspect ACME threads for defects. Remove any burrs or other visible defects. Use 1"-5 ACME-2G go/no-go gauges to gauge the ACME threads. Discard the stem if the ACME thread fails gauging.

The complete packing set (items 24, 25, 26, and 27) should be replaced.

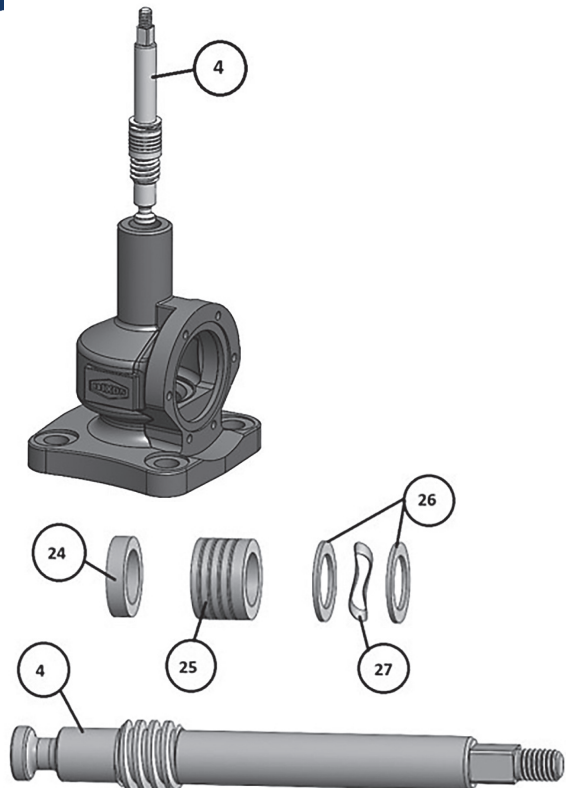

12.

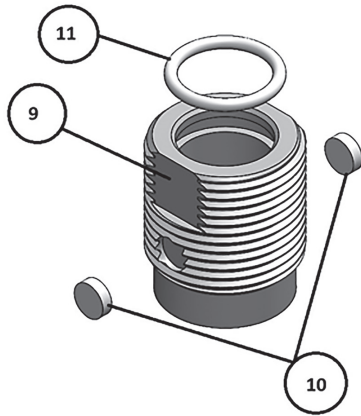

Remove the two PTFE inserts (items 10) and the O-ring (item 11) from the packing screw (item 9).

13.

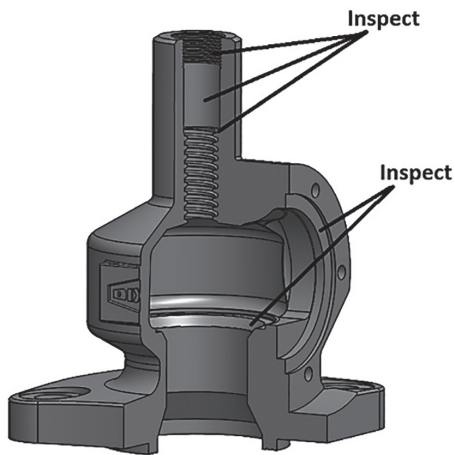

Inspect the body for corrosion. Ensure all sealing surfaces, such as packing area, outlet, and the valve seat bore are cleaned and free from pits and scratches that could form leak paths.

If excessive corrosion is present or there is damage in potential leak paths, the valve should be scrapped.

Inspect the ACME thread. It is 1"-5 ACME-2G and the packing screw thread is 1-1/4"-12 UNF-2B.

Use go/no-go gauges to inspect the threads. If the threads show significant damage or do not pass the gauge test, the valve should be scrapped.

Valve Reassembly and Requalification

Tool	Component(s)/Description	Item #
9/16" SAE socket	outlet flange hex bolts	15
deep 7/16" SAE socket or nut driver	hex lock nut on u-bolt	8
2" SAE wrench or large adjustable wrench	plug	18
1-3/4" crowfoot	packing lock nut	12
1-1/16" crowfoot	packing screw	9
5/8" SAE socket or wrench	handwheel lock nut	23
punch and hammer	spring pin	20
11/16" SAE socket	disc retainer castle nut	19
torque wrench	packing screw, disc retainer castle nut, and outlet flange hex bolts	9, 15, and 19

Sealing surfaces on body and outlet flange shall be thoroughly cleaned with cleaning agent such as semiconductor grade acetone before assembling. Torque fasteners to the appropriate value from the following table.

NOTICE: Torque values for the hex lock nuts fastening the u-bolt and handwheel lock nut are not listed. These fasteners are to be snugged and not overly torqued.

Part	Torque Value (ft-lbs)
outlet flange bolts	30
packing bushing	30
packing lock nut	65

NOTICE: Torque values provided correspond to the standard material configuration. If valve has a non-standard material configuration, contact Dixon® for appropriate values.

Install new consumable parts. The following parts are considered consumable and need to be replaced:

- O-rings
- Packing set
- Soft seat
- Spring pin
- PTFE inserts on packing screw
- Handwheel lock nut
- Handwheel washer
- Outlet flange gasket
- Outlet flange bolts
- Split lock washers

Reassembly

1.

Carefully install the O-ring (item 11) and two PTFE inserts (item 10) into the packing screw (item 9).

Ensure the O-ring is not cut or twisted during installation. A small amount of lubricant on the O-ring may help with installation.

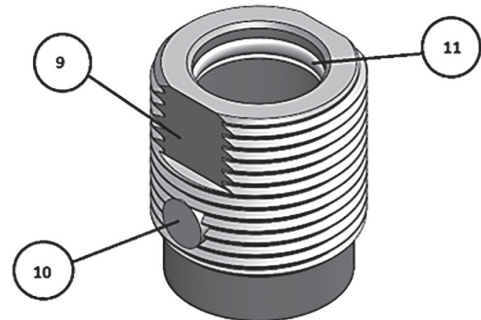

2.

Lubricate the stem sealing surface with Climax 400 or other compatible grease. Install the spacer (item 24) onto the stem as shown. Place the packing set (item 25) onto the stem (item 4) in the correct orientation with the chevrons facing downward.

Then install a washer (item 26) on top of the packing set followed by the wave spring (item 27) and the second washer (item 26). Apply Climax 400 or other compatible grease to the ACME threads on the stem (item 4) as well as the outside of the packing set (item 25). Thread the stem into the valve body and turn stem clockwise and then counterclockwise through its full range of motion a few times to evenly spread the grease.

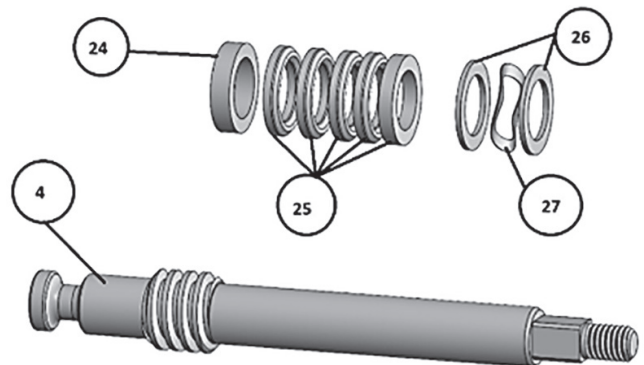

3.

Using a 1-1/16" crow's foot or adjustable wrench on the flats, install the packing screw (item 9) into the body torquing to 30 ft-lbs.

Using a 1-3/4" crow's foot or adjustable wrench, install the packing locknut (item 12) onto the packing screw (item 9) torquing to 65 ft-lbs. The packing locknut should be tight against the top of the valve body.

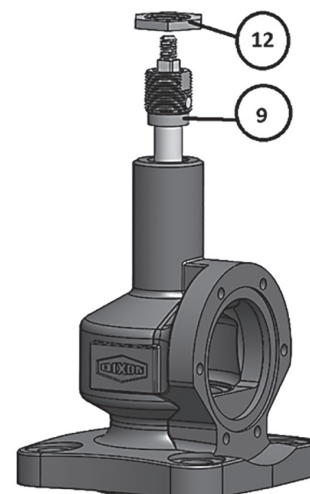

4.

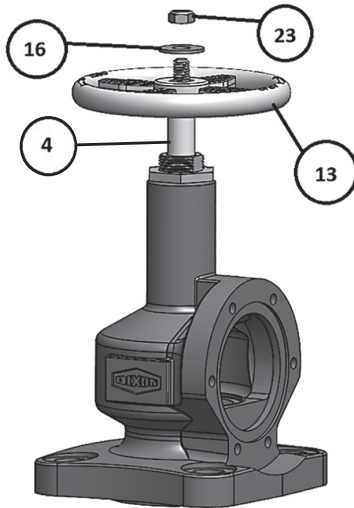

Install handwheel (item 13) onto the square portion of the stem (item 4). Place the handwheel washer (item 16) on top of the handwheel. Thread the lock nut (item 23) onto the end of the stem and with a 5/8" socket, firmly snug it against the handwheel washer.

5.

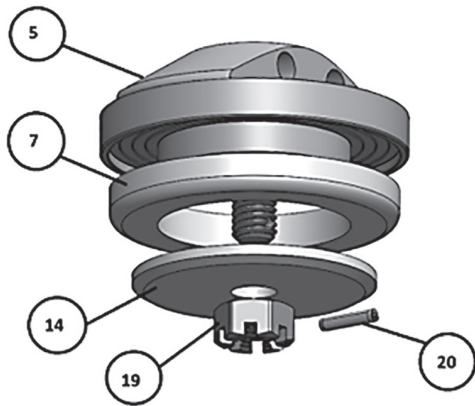

Install the soft seat (item 7) into the seat retainer (item 5). Place the disc washer (item 14) over the threaded portion of the seal retainer (item 5). Thread on the disc retainer castle nut (item 19).

Using an 11/16" socket, tighten the disc retainer castle nut (Item 19) to 35 ft-lbs. If necessary, tighten further until the slots in the castle nut line up with the hole in the seal retainer (Item 5).

Punch the spring pin (Item 20) into the through hole on the seal retainer (Item 5) until it is centered with equal lengths sticking out of each side.

6.

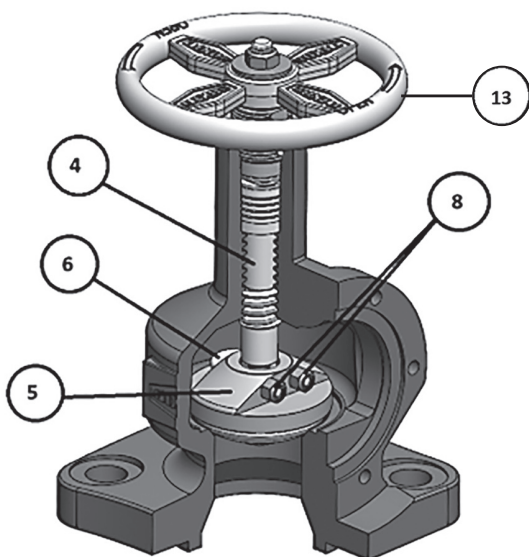

Using the handwheel (item 13), open the valve. Place the seal retainer (item 5) into the body with the holes at the top of the seal retainer facing the side outlet of the valve. Close the valve until the stem bottoms out on the seat retainer (item 5), then open the valve approximately 1/4 turn.

Insert the u-bolt (item 6) into the holes on the seat retainer (item 5) retaining the end of the stem (item 4). Rotate the seat retainer (item 5) 180° until the threads on the u-bolt (item 6) are facing the side outlet. Lightly hold one thread on the u-bolt (item 6) and install a hex lock nut (item 8) on the other thread. Install the other hex lock nut (item 8) on the other side of the u-bolt (item 6). Use a deep 7/16" socket to tighten the hex lock nuts (item 8) until they are snug. It is not necessary to overtighten them.

Using the handwheel (item 13), open the valve one turn. Check that the seat retainer moves freely on the stem.

7.

Apply a thin layer of a Climax 400 or other compatible grease to the outlet flange gasket (Item 3) and install into the groove on the valve body. Firmly press the outlet flange (Item 2) into the valve body taking care not to damage the outlet flange sealing surfaces.

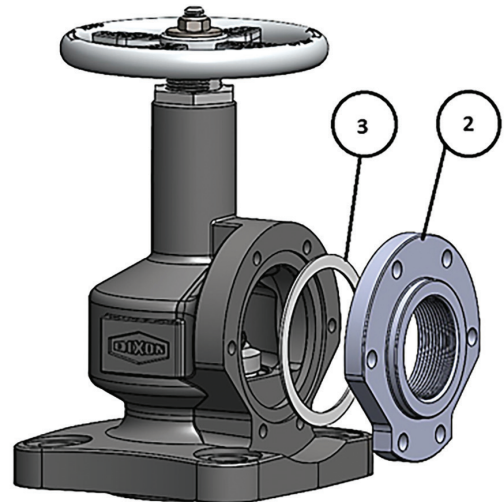

8.

Using a 9/16" socket, install hex bolts (items 15) with split lock washers (items 17), fastening the outlet flange to the body in a star pattern as indicated below. Torque the hex bolts (items 15) to 30 ft-lbs .

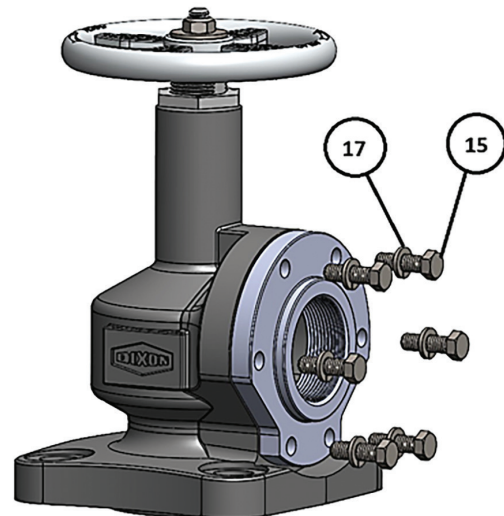
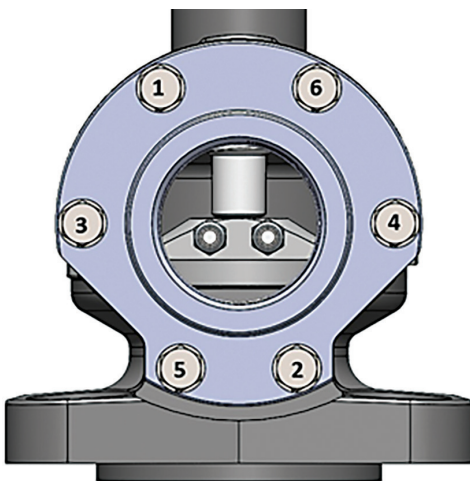

9.

Apply pipe thread sealant to the threads of the plug in, the plug/chain assembly (item 18), and install it into the outlet flange. Remove the handwheel (item 13) and place the chain loop over the neck of the body (item 1). Re-install the handwheel (item 13) using the same steps as outlined above.

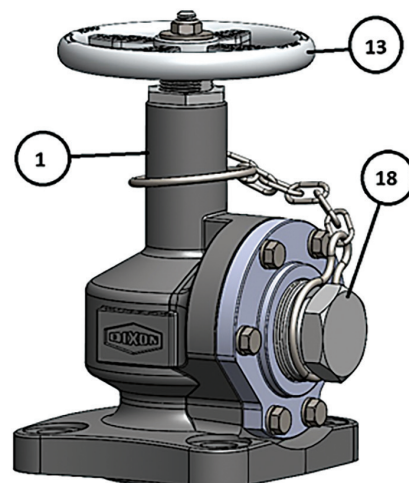

Requalification

Seat Seal Test:

Secure the valve onto a test fixture with the correct gasket.

Close the valve applying up to 30 ft-lbs. of torque to the handwheel. Remove the outlet plug and perform a seat test using a suitable method per your company's procedure. Check for any signs of leakage past the seat.

Release the pressure from the valve and fully open it.

Shell Seal Test:

With the valve still mounted to the test fixture, use the handwheel (Item 13) to open the valve. Install the outlet plug (Item 18) so that it is sealed to the flange. Perform a shell seal test following your company's procedure. Check for leaks at the valve stem packing area, between the body and the outlet flange and around the outlet plug using a suitable method.

Once complete, depressurize the valve.



WARNING: Toxic Hazard: Always use extreme caution and proper equipment when involved with hazardous materials. To avoid exposure to toxic or hazardous materials, make sure the tank car is empty and clean, and that the work area is free of hazardous chemicals before removing or installing any valve.

Wipe or blow away any liquids remaining on the valve from testing.

Put the plastic endcap back over the valve body tongue.

Routine Maintenance

Periodic checks with a bubble leak detector fluid at the packing area, outlet flange interface, tongue and groove seal at the bottom of the valve, and the plug are recommended to ensure the integrity of the sealing surfaces.

Measure the gap between the bottom of the handwheel (Item 13) and the top of the packing lock nut (Item 12) when the valve is fully closed. If the gap measures less than 0.400", the soft seat is excessively deformed and needs replacement.

The top of the packing screw (Item 9) should not be less than 0.200" from the top of the lacking lock nut (Item 12). If the packing screw is threaded down more than this, the packing set is overly worn and must be replaced.

Operation

Never use a wrench or any other handle extension to turn the handwheel. The handwheel is designed to break with excess torque to prevent damage to the valve. The valve is designed to seal with 20 to 30 ft-lbs. of torque applied to the handwheel.

To close the valve, turn the handwheel clockwise. To open the valve, turn the handwheel counterclockwise as shown on the nameplate.

Ensure packing screw is torqued to a minimum of 30 ft-lbs. If leaking through the packing is detected, tighten packing screw until leak stops. Avoid unnecessary overtightening as it will cause excessive friction against the stem.

Emergency Response for Leaking Valve

Emergency response is the temporary remediation to a valve observed to be releasing product in an unintended manner. Close the valve using the handwheel, install the outlet plug and tighten the packing bushing. If leaking continues, install a capping kit over the valve. Once the car is unloaded and pressure is relieved, the valve should be removed for a complete inspection and repair, and qualification to the car owner's standard qualification and maintenance program. Leak repairs are unscheduled and not part of regular maintenance.

This manual is not intended to provide all the information necessary to complete emergency maintenance. Personnel must be specifically trained and qualified in hazmat procedures before attempting to service a leaking valve.

Limited Warranty

DIXON VALVE AND COUPLING COMPANY, LLC (herein called "Dixon") warrants the products described herein and manufactured by Dixon to be free from defects in material and workmanship for a period of one (1) year from date of shipment by Dixon under normal use and service. Its sole obligation under this warranty being limited to repairing or replacing, as hereinafter provided, at its option any product found to Dixon's satisfaction to be defective upon examination by it, provided that such product shall be returned for inspection to Dixon's factory within three (3) months after discovery of the defect. The repair or replacement of defective products will be made without charge for parts or labor. This warranty shall not apply to: (a) parts or products not manufactured by Dixon, the warranty of such items being limited to the actual warranty extended to Dixon by its supplier; (b) any product that has been subject to abuse, negligence, accident, or misapplication; (c) any product altered or repaired by others than Dixon; and (d) to normal maintenance services and the replacement of service items (such as washers, gaskets, and lubricants) made in connection with such services. To the extent permitted by law, this limited warranty shall extend only to the buyer and any other person reasonably expected to use or consume the goods who is injured in person by any breach of the warranty. No action may be brought against Dixon for an alleged breach of warranty unless such action is instituted within one (1) year from the date the cause of action accrues. This limited warranty shall be construed and enforced to the fullest extent allowable by applicable law.

Other than the obligation of Dixon set forth herein, Dixon disclaims all warranties, express or implied, including but not limited to any implied warranties of merchantability or fitness for a particular purpose, and any other obligation or liability. The foregoing constitutes Dixon's sole obligation with respect to damages, whether direct, incidental or consequential, resulting from the use or performance of the product.

Some products and sizes may be discontinued when stock is depleted or may require a minimum quantity for ordering.

