

Table of Contents

Swivel Joint Overview 3-7

- New products 4
- Operations / Service 5
- Swivel color and etching identification 6
- Swivel joint styles 7

O-Ring Swivel Joints 8-21

- Overview 8
- Exploded view / Part number key 8
- Configurations / Parts 9-19
- Rebuild kits 20
- Seal replacement 21

V-Ring Swivel Joints 22-32

- Overview 22
- Exploded view / Part number key 22
- Configurations / Parts 23-30
- Rebuild kits 31
- Seal replacement 32

Cap Seal Swivel Joints 33-39

- Overview / Exploded view 33
- Part number key 34
- Configurations / Parts 34-37
- Seal replacement 38-39

Split Flange Swivel Joints 40-48

- Overview 40
- Exploded view / Part number key 40
- Configurations / Parts 41-47
- Components 47
- Seal replacement 48

High Capacity Split Flange Swivel Joints 49-57

- Overview 49
- Exploded view / Part number key 49
- Configurations / Parts 50-55
- Components 56
- Seal Replacement 57

Loading Arms 58-61

- Overview 58
- Configurations / Parts 58-59
- Base swivels with counterbalance 60
- Loading arm swivels 61

Table of Contents

Swivel Joint Accessories	62-67
Flanges / Gaskets	62-64
Pipe fittings, half couplings, grease fittings, set screws	65
Handle kits.....	66
Thread sealant.....	66
Joint sealant gasket materials.....	66
PTFE tape	67
Safety & Technical	68-71
Bolt tightening sequence.....	68
Flange diagrams.....	68
ANSI flange dimensions	69
Pressure rating chart	70
Limited warranty / Safety	71

Swivel Joints Overview

Applications

- Used wherever a leak-proof swivel connection is needed in pipelines or in combination with hoses to eliminate hose twisting.
- Ideal for a wide range of industries including petroleum, petrochemical, refining, mining, distilling, paint, farm irrigation and fertilizing, wastewater treatment plants, and food and beverage process equipment. Dixon® swivel joints are commonly used in blending plants, drum filling applications, fluid and dry bulk transfer, vacuum trucks, oil and gas trucks and water trucks. Larger swivels can be found in the steel industry, marine bulk transfer, and many more applications.

Features

- Full 360° rotational movement
- 100% full penetration weld
- Wide spacing between dual ball bearing raceways ensures greater load bearing capacity
- Precision-machined design ensures alignment and years of trouble-free service
- O-ring dust seal protects the ball races and seals chamber from outside elements
- Radius elbow design ensures a smooth flow path
- All swivels undergo rigorous hydrostatic testing prior to shipment to ensure performance and reliability, with the exception of weld end swivels, which are prepared for customer-specific testing after installation.

Additional Options

- End configurations: male NPT, female NPT, 150# flange, TTMA flange, grooved, weld end, and others upon request.
- Seal options: nitrile rubber, FKM, PTFE, EPDM, FDA nitrile rubber, and low temperature FKM
- Ball bearing materials: carbon steel, 440 stainless steel, and 316 stainless steel
- Grease materials: Lithium, FDA approved/food grade, silicone, and low temperature grease
- Swivels that include oxygen, steam, submerged, or vacuum service can be specifically designed for unique applications (special order)
- Swivel Joint Types: O-ring, V-ring, Split Flange, Cap Seal, and High Capacity Split Flange
- Locking mechanism for split flange swivels
- Epoxy paint
- Re-build kits available
- Custom swivel options available; contact Dixon at 877.963.4966

Swivel configurator available at dixonvalve.com

New Products

14"-24" Cap Seal Swivel Joints

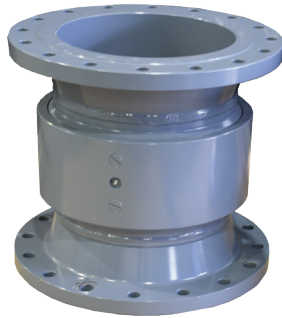

Pg. 33

14" V-Ring Swivel Joints



Pg. 22

Aluminum Nose Pieces for Split Flange Swivel Joints



Pg. 40

High Capacity Split Flange Swivel Joints



Pg. 49

4" Ductile Iron O-Ring Style Swivel Joints



Pg. 9

Total Rebuild Kits for O-Ring Swivels



Pg. 20

Total Rebuild Kits for V-Ring Swivels



Pg. 31

TTMA Gasket Kits



Pg.62

150 lb. Flange Gasket Kits



Pg. 63

Operation / Service

Dixon® swivels are recommended for use at the following maximum Non-Shock Cold Working Pressures (NSCWP) provided in **PSI** at ambient temperature **70°F (21°C)** for 1" – 24" sizes:

- See pressure rating chart on pg. 70 
- When using flanged ends, the pressure rating will be reduced to coincide with that of the flange being used. Carbon steel and stainless steel 150# flanges are recommended for use at **275 PSI** maximum and 300# flanges at **740 PSI** at ambient temperature **70°F (21°C)**.
- TTMA flanges are recommended for use to **150 PSI** maximum at ambient temperature **70°F (21°C)**.
- Lubrication should be performed periodically, depending on service and operation conditions. Biannually is normally sufficient.
- All dimensions are approximate. Where critical, consult Dixon.

Use with Hose

When using swivel joints to compensate for hose twist (e.g., Style 20 or Style 60), careful consideration is needed. The hose must be stiff enough to generate sufficient torque to activate the swivel before kinking occurs.

In many cases, lateral movement-induced twist can be resolved with a swivel joint (e.g., Style 40 or Style 30). If not, hose swivels may offer a solution. These non-ball bearing designs require less torque for rotation but are not intended for load-bearing applications.

It's important to note that some hoses, such as many metal hoses, may not produce enough torque to rotate even a hose swivel. On the other hand, stiffer hoses, like many armored hoses, can easily turn most swivels.

Pricing

Pricing is available upon request. Please contact Dixon for assistance with pricing and selecting the right equipment for your specific application.

Each swivel joint is custom-built to order, so returns are generally not accepted. However, return requests will be considered on a case-by-case basis. Approved returns will be subject to a restocking fee of 15%, along with any additional costs incurred.

S.T.A.M.P.E.D.

When fabricating and specifying assemblies ask the following questions:

- Size:** What is the I.D. (inside diameter)? What is the O.D. (outside diameter)? What is the overall length of the assembly required?
- Temperature:** What is the temperature range of the media (product) that is flowing through the assembly? What is the temperature range of the environment that surrounds the outside of the assembly?
- Application:** How is the assembly actually being used? Is it a pressure application? Is it a vacuum (suction) application? Is it a gravity flow application? Are there any special requirements that the assembly is expected to perform? Is the assembly being used in a horizontal or vertical position? Are there any pulsations or vibrations acting on the assembly?
- Media:** What is the media/material that is flowing through the assembly? Being specific is critical. Check for: Abrasive materials, chemical compatibility, etc.
- Pressure:** What is the maximum pressure including surges (or, maximum vacuum) that this assembly will be subjected to? Always rate the maximum working pressure of your assembly by the lowest rated component in the system.
- Ends:** What end connection has been requested by the user? Are they the proper fittings for the application?
- Dixon:** Be Safe: Any questions on application, use, or assembly, call 877.963.4966.

Color Identification

Color identification is important in manufacturing processes because it aids in quickly distinguishing differences between parts, materials and assembly stages, thereby reducing errors and improving efficiency. At times color identification can also clarify the type of media that is flowing through a piping system. However, for the standard Dixon Swivel Joints the color or finish aids in identifying the material and seal design.

O-Ring



Aluminum



Brass



Ductile Iron

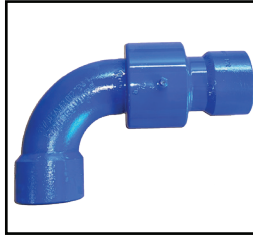

Carbon Steel



Stainless Steel

V-Ring / Cap Seal



Aluminum

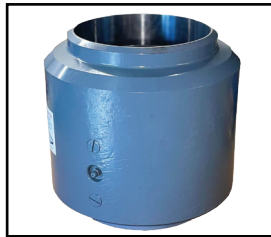

Carbon Steel



Stainless Steel

Split Flange / High Capacity



Aluminum



Carbon Steel



Stainless Steel

Part Number Etching Identification

Dixon Swivel Joints are etched with their unique part number for accurate identification. This practice supports quality control and inventory management. Additionally, the etched identification helps simplify maintenance and replacement, as it allows quick reference to specific parts in technical documentation and service records.



Swivel Joint Styles

Single Plane



style 20

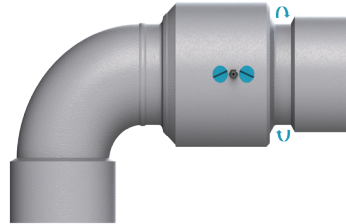

style 30

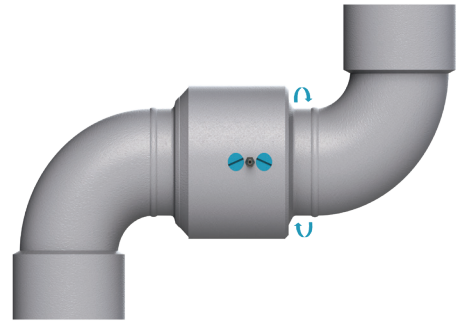

style 40

Double Plane

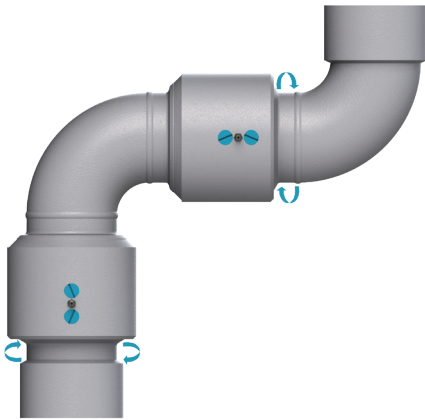

style 50

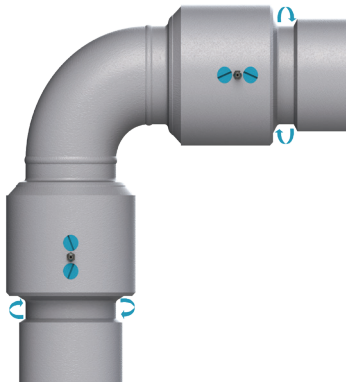

style 60

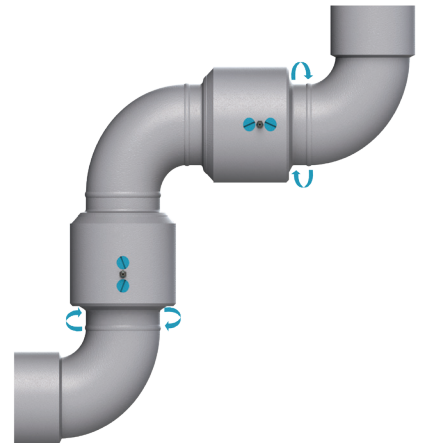

style 70

Triple Plane

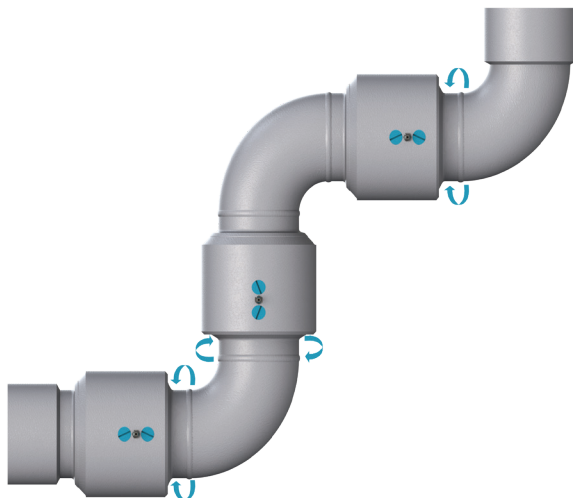

style 80

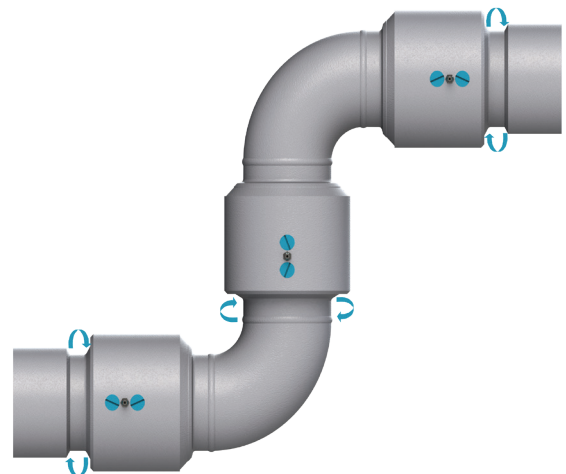

style 10

O-Ring Swivel Joints

Applications

- Commonly used in tote/drum loading, loading arms, hose and steam, water supply lines, tank trucks, compressed air, asphalt, irrigation, suction and vacuum, petroleum, and mining.

Sizes

- 1" - 4"

Features

- O-ring pressure seal ensures a leak-proof seal and smooth rotation with lower torque
- Smooth moving seal for high-volume drum and tote loading
- Available working pressure ratings up to **1,000 PSI**, based on material and end connections
- Available end connections include: 150 lbs. and 300 lbs. flanges, FNPT, MNPT, butt weld, TTMA, and others upon request
- End connections and materials offered may vary based on size, contact Dixon® for details

Materials

- Available materials include carbon steel, 316L stainless steel, aluminum, brass, and ductile iron

Bill of Materials

1. Body
2. Sleeve
3. Ball bearings
4. Grease fitting
5. Ball retainer screws
6. O-ring (dust seal)
7. O-ring (pressure seal)

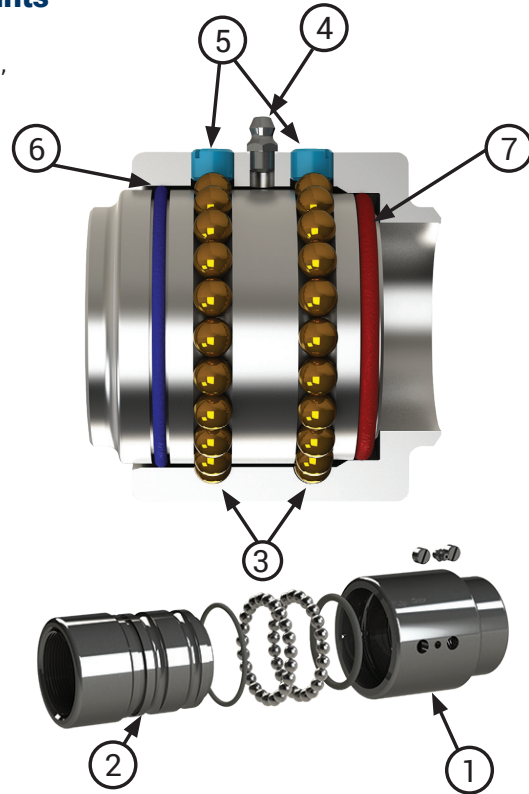

O-Ring Swivel Joint Numbering System

2	20	F	x	F	OC	0	0	0	0	0
Sizes Inches	Style*	End Connection	x	End Connection	Material	Pressure Seal	Dust Seal	Retainers	Ball Bearings	Grease
1 = 1"	20	F (FNPT)	x	F (FNPT)	AL = aluminum	0 = nitrile rubber	0 = nitrile rubber	0 = no retainer	0 = carbon steel	0 = lithium
125 = 1-1/4"	30	W (weld)	x	W (weld)	BR = brass	1 = FKM	1 = FKM		1 = 440 stainless steel	1 = food grade
150 = 1-1/2"	40	FG (150#)	x	FG (150#)	MI = ductile iron	2 = PTFE			2 = 316 stainless steel	2 = silicone
2 = 2"	50	PF (300#)	x	PF (300#)	OC = O-ring carbon steel	3 = EPDM	3 = EPDM			3 = Tribolube
3 = 3"	60	TF (TTMA)	x	TF (TTMA)	OS = O-ring 316 stainless steel	4 = FDA nitrile rubber	4 = FDA nitrile rubber			4 = low temperature
4 = 4"	70	BP (BSPP)	x	BP (BSPP)		5 = No seal	5 = No seal			5 = no grease
	80	BT (BSPT)	x	BT (BSPT)		A = Low Temp FKM				
	10	G (groove)	x	G (groove)						
		M (MNPT)	x	M (MNPT)						

*If ordering a handle, the zero would be replaced by H or B. Use "H" for a heavy-duty D-style shovel handle.

NOTE: Other end connections or seals are available upon request.

- Brass O-ring: 1-1/2" - 3"
- Ductile iron O-ring: 1-1/2" - 4"
- Standard grease fitting without ball check on all O-ring Swivel Joint materials except 316 stainless steel. Ask for check ball if required. 316 SS O-ring Swivel Joints include SS grease fitting with ball check.
- Dixon® does not offer 4" O-ring configuration for stainless steel material.

O-Ring Style 20 - Weld x Weld

Size	Part #	Material	Weight (lbs)	Dimension A
1"	120WXW	OC - carbon steel	3	2-7/8"
		OS - stainless steel	3	
1-1/2"	15020WXW	OC - carbon steel	3	3-3/16"
		OS - stainless steel	3	
		AL - aluminum	1	3-13/16"
2"	220WXW	OC - carbon steel	5	3-9/16"
		OS - stainless steel	5	
		AL - aluminum	3	5-3/8"
3"	320WXW	OC - carbon steel	7	4-1/8"
		OS - stainless steel	7	
		AL - aluminum	4	5-11/16"
4"	420WXW	OC - carbon steel	21	6"
		AL - aluminum	7	7-5/16"

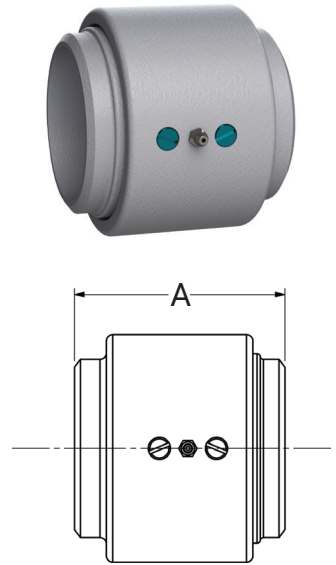

O-Ring Style 20 - FNPT x FNPT

Size	Part #	Material	Weight (lbs)	Dimension A
1"	120FXF	OC - carbon steel	3	3-15/16"
		OS - stainless steel	3	
		AL - aluminum	1	
1-1/4"	12520FXF	AL - aluminum	1	3-31/32"
1-1/2"	15020FXF	OC - carbon steel	4	4"
		OS - stainless steel	4	
		AL - aluminum	1	
		BR - brass	4	
		MI - ductile iron	4	
2"	220FXF	OC - carbon steel	6	5-9/16"
		OS - stainless steel	7	
		AL - aluminum	4	
		BR - brass	9	
		MI - ductile iron	8	
3"	320FXF	OC - carbon steel	9	5-7/8"
		OS - stainless steel	9	
		AL - aluminum	4	5-29/32"
		BR - brass	11	
4"	420FXF	OC - carbon steel	34	10-3/4"
		AL - aluminum	7	7-5/8"
		MI - ductile Iron	18	

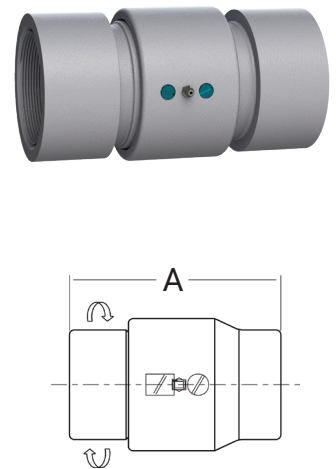

O-Ring Style 20 - 150# Flange x 150# Flange

Size	Part #	Material	Weight (lbs)	Dimension A
1"	120FGXFG	OS - stainless steel	8	7-9/32"
		OC - carbon steel		
1-1/2"	1520FGFG	OC - carbon steel	12	8-1/16"
		OS - stainless steel	12	
		AL - aluminum	4	8-11/16"
2"	220FGXFG	OC - carbon steel	17	8-17/32"
		OS - stainless steel	17	
		AL - aluminum	8	10-3/8"
3"	320FGXFG	OC - carbon steel	31	9-5/8"
		OS - stainless steel	31	
		AL - aluminum	10	11-5/32"
4"	420FGXFG	OC - carbon steel	51	12"
		AL - aluminum	13	13-5/16"

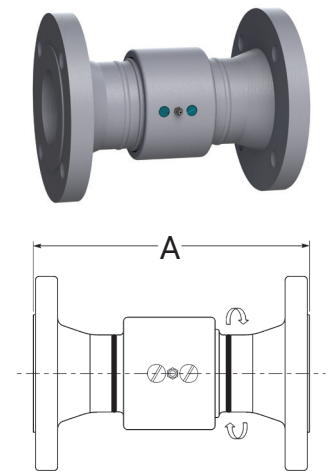

O-Ring Style 30 - FNPT x FNPT

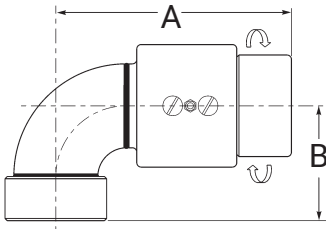

Size	Part #	Material	Weight (lbs)	Dimensions	
				A	B
1"	130FXF	OC - carbon steel	4	4-13/32"	2-3/16"
		OS - stainless steel	3	5-29/32"	2-11/16"
1-1/2"	15030FXF	OC - carbon steel	5	5-7/16"	3-15/32"
		OS - stainless steel	6		
		AL - aluminum	2	4-11/16"	3"
		BR - brass	5		
		MI - ductile iron	5		
2"	230FXF	OC - carbon steel	8	6-21/32"	3-1/4"
		OS - stainless steel	6		
		AL - aluminum	4	6-3/16"	2-7/8"
		BR - brass	10		
		MI - ductile iron	9		
3"	330FXF	OC - carbon steel	13	8-9/64"	4-13/16"
		OS - stainless steel	13		
		AL - aluminum	5	7-1/16"	3-7/8"
		BR - brass	15		
		MI - ductile iron	13		
4"	430FXF	OC - carbon steel	40	12-3/8"	6-3/8"
		AL - aluminum	9	9-1/8"	4-3/4"

O-Ring Style 30 - 150# Flange x 150# Flange

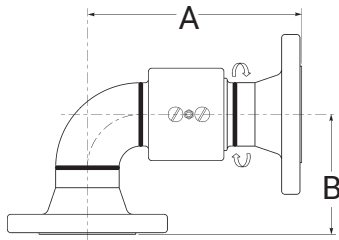

Size	Part #	Material	Weight (lbs)	Dimensions	
				A	B
1"	130FGXFG	OC - carbon steel	8	6-3/32"	3-3/16"
		OS - stainless steel	8	6-19/32"	3-11/16"
1-1/2"	1530FGFG	OC - carbon steel	12	7-7/8"	4-11/16"
		OS - stainless steel	12		
		AL - aluminum	4	7-1/32"	5-11/32"
2"	230FGXFG	OC - carbon steel	20	8-1/32"	4-1/2"
		OS - stainless steel	20		
		AL - aluminum	8	8-5/8"	5-9/32"
3"	330FGXFG	OC - carbon steel	33	9-7/8"	5-3/4"
		OS - stainless steel	33		
		AL - aluminum	13	9-11/16"	6-15/32"
4"	430FGXFG	OC - carbon steel	57	13"	7"
		AL - aluminum	14	11-31/32"	7-19/32"

O-Ring Style 30 - TTMA Flange x TTMA Flange

Size	Part #	Material	Weight (lbs)	Dimensions	
				A	B
2"	230TFXTF	OC - carbon steel	8	5-5/8"	5-1/8"
		OS - stainless steel	7		
		AL - aluminum	5		
3"	330TFXTF	OC - carbon steel	14	8-1/2"	4-3/8"
		OS - stainless steel	15		
		AL - aluminum	6	7-3/4"	4-15/16"
4"	430TFXTF	OC - carbon steel	30	10-1/4"	4-1/4"
		AL - aluminum	12	8-7/8"	5-17/32"

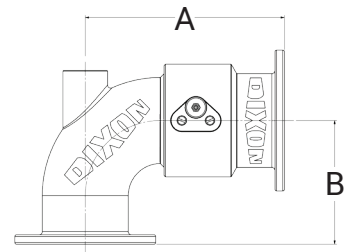

O-Ring Style 30 - TTMA Flange x TTMA Flange with D-Handle

Size	Part #	Material	Weight (lbs)	Dimensions	
				A	B
2"	23HTFXTF	OC - carbon steel	10	5-5/8"	5-1/8"
		OS - stainless steel	9		
		AL - aluminum	7		
3"	33HTFXTF	OC - carbon steel	17	8-1/2"	4-3/8"
		OS - stainless steel	17		
		AL - aluminum	8	7-3/4"	4-15/16"
4"	43HTFXTF	OC - carbon steel	33	10-1/4"	4-1/4"
		AL - aluminum	14	8-7/8"	5-17/32"

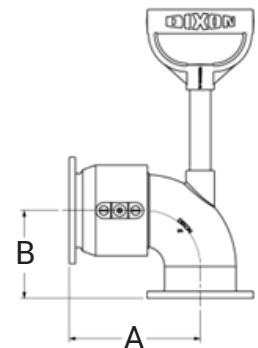

O-Ring Style 40 - FNPT x FNPT

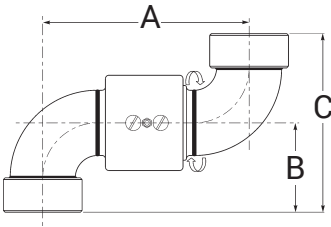

Size	Part #	Material	Weight (lbs)	Dimensions		
				A	B	C
1"	140FXF	OC - carbon steel	4	4-59/64"	2-3/16"	4-3/8"
		OS - stainless steel	4	5-59/64"	2-11/16"	5-3/8"
1-1/2"	15040FXF	OC - carbon steel	7	7-11/16"	3-15/32"	6-15/16"
		OS - stainless steel	7			
		AL - aluminum	2	6-1/8"	3"	6"
		BR - brass	7			
		MI - ductile iron	6			
2"	240FXF	OC - carbon steel	9	7-17/32"	3-1/4"	6-1/2"
		OS - stainless steel	9			
		AL - aluminum	5	6-11/16"	2-7/8"	5-3/4"
		BR - brass	11			
		MI - ductile iron	9			
3"	340FXF	OC - carbon steel	18	10-1/8"	4-13/16"	9-5/8"
		OS - stainless steel	18			
		AL - aluminum	6	8-1/4"	3-7/8"	7-3/4"
		BR - brass	18			
		MI - ductile iron	15			
4"	440FXF	OC - carbon steel	45	14"	6-3/8"	12-3/4"
		AL - aluminum	10	10-5/8"	4-3/4"	9-1/2"

O-Ring Style 40 - 150# Flange x 150# Flange

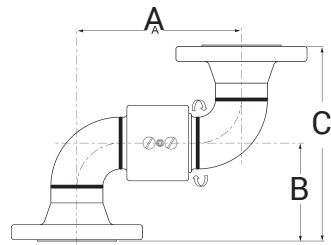

Size	Part #	Material	Weight (lbs)	Dimensions		
				A	B	C
1"	140FGXFG	OC - carbon steel	9	4-59/64"	3-3/16"	6-3/8"
		OS - stainless steel	9	5-59/64"	3-11/16"	7-3/8"
1-1/2"	15040FGXFG	OC - carbon steel	13	7-11/16"	4-11/16"	9-3/8"
		OS - stainless steel	13			
		AL - aluminum	4	6-1/8"	5-11/32"	5-11/16"
2"	240FGXFG	OC - carbon steel	21	7-17/32"	4-1/2"	9"
		OS - stainless steel	21			
		AL - aluminum	8	6-11/16"	5-9/32"	10-9/16"
3"	340FGXFG	OC - carbon steel	40	10-1/8"	5-3/4"	11-1/2"
		OS - stainless steel	40			
		AL - aluminum	11	8-1/4"	6-5/8"	13-1/4"
4"	440FGXFG	OC - carbon steel	62	14"	7"	14"
		AL - aluminum	16	10-5/8"	7-9/16"	15-1/8"

O-Ring Style 40 - TTMA Flange x TTMA Flange

Size	Part #	Material	Weight (lbs)	Dimensions		
				A	B	C
2"	240TFXTF	OC - carbon steel	8	7-17/32"	5-1/8"	10-1/4"
		OS - stainless steel	8			
		AL - aluminum	4	6-11/16"	5-1/8"	10-1/4"
3"	340TFXTF	OC - carbon steel	17	10-1/8"	4-3/8"	8-3/4"
		OS - stainless steel	18			
		AL - aluminum	7	9-9/64"	4-15/16"	9-7/8"
4"	440TFXTF	OC - carbon steel	36	14"	4-1/4"	8-1/2"
		AL - aluminum	17	10-5/8"	6-9/16"	13-1/8"

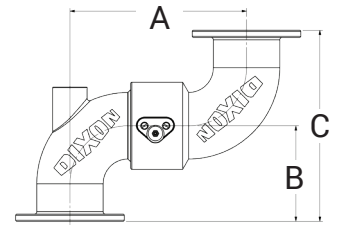

O-Ring Style 40 - TTMA Flange x TTMA Flange with D-handle

Size	Part #	Material	Weight (lbs)	Dimensions		
				A	B	C
2"	24HTFXTF	OC - carbon steel	10	7-17/32"	5-1/8"	10-1/4"
		OS - stainless steel	10			
		AL - aluminum	6	6-11/16"	5-1/8"	10-1/4"
3"	34HTFXTF	OC - carbon steel	18	10-1/8"	4-3/8"	8-3/4"
		OS - stainless steel	18			
		AL - aluminum	9	9-9/64"	4-15/16"	9-7/8"
4"	44HTFXTF	OC - carbon steel	39	14"	4-1/4"	8-1/2"
		AL - aluminum	19	10-5/8"	6-9/16"	13-1/8"

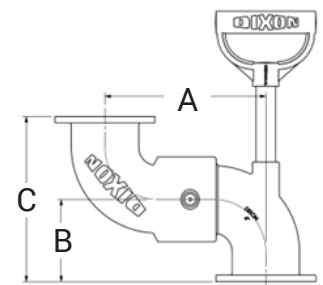

O-Ring Style 50 - FNPT x FNPT

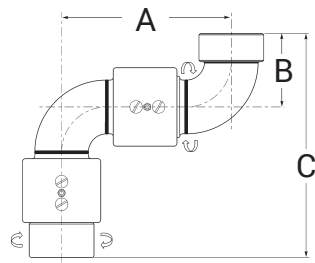

Size	Part #	Material	Weight (lbs)	Dimensions		
				A	B	C
1"	150FXF	OC - carbon steel	7	4-59/64"	2-3/16"	6-3/32"
		OS - stainless steel	7	5-59/64"	2-11/16"	7-19/32"
1-1/2"	15050FXF	OC - carbon steel	9	7-11/16"	3-15/32"	8-29/32"
		OS - stainless steel	9			
		AL - aluminum	3	6-1/8"	3"	7-11/16"
2"	250FXF	OC - carbon steel	14	7-17/32"	3-1/4"	9-29/32"
		OS - stainless steel	14			
		AL - aluminum	8	6-11/16"	2-7/8"	9-1/16"
		BR - brass	15			
MI - ductile iron	13					
3"	350FXF	OC - carbon steel	22	10-1/8"	4-13/16"	12-61/64"
		OS - stainless steel	22			
		AL - aluminum	9	8-1/4"	3-7/8"	10-29/32"
		MI - ductile iron	22			
4"	450FXF	OC - carbon steel	67	14"	6-3/8"	18-3/4"
		AL - aluminum	15	10-5/8"	4-3/4"	13-7/8"

O-Ring Style 50 - 150# Flange x 150# Flange

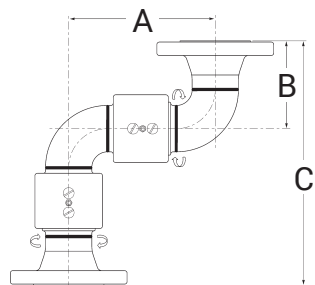

Size	Part #	Material	Weight (lbs)	Dimensions		
				A	B	C
1"	150FGXFG	OC - carbon steel	11	4-59/64"	3-3/16"	9-19/64"
		OS - stainless steel	11	5-59/64"	3-11/16"	10-19/64"
1-1/2"	1550FGFG	OC - carbon steel	14	7-11/16"	4-11/16"	12-9/16"
		OS - stainless steel	14			
		AL - aluminum	6	6-1/8"	5-11/32"	12-3/8"
2"	250FGXFG	OC - carbon steel	23	7-17/32"	4-1/2"	12-17/32"
		OS - stainless steel	23			
		AL - aluminum	12	6-11/16"	5-9/32"	13-29/32"
3"	350FGXFG	OC - carbon steel	38	10-1/8"	5-3/4"	15-5/8"
		OS - stainless steel	38			
		AL - aluminum	17	8-1/4"	6-15/32"	16-3/32"
4"	450FGXFG	OC - carbon steel	83	10-5/8"	7-19/32"	19-9/16"
		AL - aluminum	26	10-5/8"	7-19/32"	19-9/16"

O-Ring Style 50 - TTMA Flange x TTMA Flange

Size	Part #	Material	Weight (lbs)	Dimension A	Dimension B	Dimension C
2"	250TFXTF	OC - carbon steel	13	7-17/32"	2-3/16"	9-13/32"
		OS - stainless steel	13			
		AL - aluminum	9			
3"	350TFXTF	OC - carbon steel	24	10-1/8"	3-1/8"	12"
		OS - stainless steel	23			
		AL - aluminum	9			
4"	450TFXTF	OC - carbon steel	57	14"	4-1/4"	14-1/2"
		AL - aluminum	16	10-5/8"	5-1/2"	14-3/16"

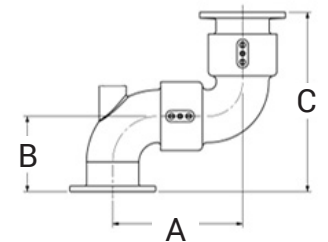

O-Ring Style 50 - TTMA Flange x TTMA Flange with D-handle

Size	Part #	Material	Weight (lbs)	Dimension A	Dimension B	Dimension C
2"	25HTFXTF	OC - carbon steel	17	7-17/32"	2-3/16"	9-13/32"
		OS - stainless steel	17			
		AL - aluminum	11			
3"	35HTFXTF	OC - carbon steel	27	10-1/8"	3-1/8"	12"
		OS - stainless steel	26			
		AL - aluminum	11			
4"	45HTFXTF	OC - carbon steel	60	14"	4-1/4"	14-1/2"
		AL - aluminum	19	10-5/8"	5-1/2"	14-3/16"

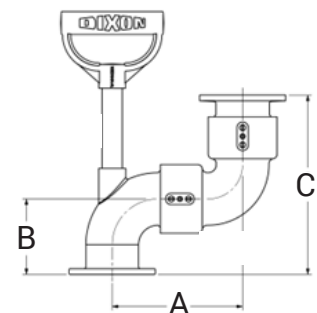

O-Ring Style 60 - FNPT x FNPT

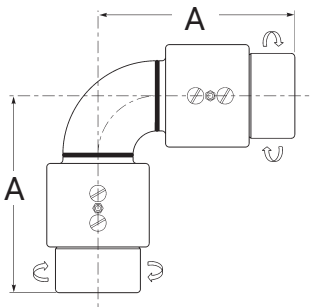

Size	Part #	Material	Weight (lbs)	Dimension A
1"	160FXF	OC - carbon steel	6	4-13/32"
		OS - stainless steel	6	4-29/32"
1-1/2"	15060FXF	OC - carbon steel	9	5-7/16"
		OS - stainless steel	9	
		AL - aluminum	3	4-11/16"
2"	260FXF	OC - carbon steel	13	6-21/32"
		OS - stainless steel	13	
		AL - aluminum	7	6-7/32"
		BR - brass	14	
		MI - ductile iron	13	
3"	360FXF	OC - carbon steel	23	8-9/64"
		OS - stainless steel	23	
		AL - aluminum	9	7-1/32"
		MI - ductile iron	19	
4"	460FXF	OC - carbon steel	61	12-3/8"
		AL - aluminum	13	9-1/8"

O-Ring Style 60 - 150# Flange x 150# Flange

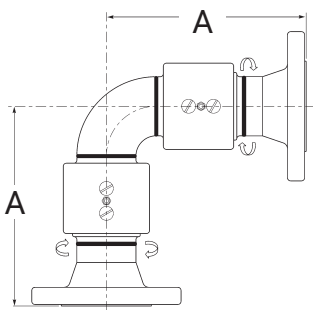

Size	Part #	Material	Weight (lbs)	Dimension A
1"	160FGXFG	OC - carbon steel	11	6-7/64"
		OS - stainless steel	11	6-39/64"
1-1/2"	1560FGFG	OC - carbon steel	13	7-7/8"
		OS - stainless steel	13	
		AL - aluminum	6	7-1/32"
2"	260FGXFG	OC - carbon steel	25	8-1/32"
		OS - stainless steel	25	
		AL - aluminum	11	8-5/8"
3"	360FGXFG	OC - carbon steel	35	9-7/8"
		OS - stainless steel	35	
		AL - aluminum	16	9-5/8"
4"	460FGXFG	OC - carbon steel	78	13"
		AL - aluminum	23	11-31/32"

O-Ring Style 70 - FNPT x FNPT

Size	Part #	Material	Weight (lbs)	Dimensions	
				A	B
1"	170FXF	OC - carbon steel	8	4-59/64"	2-3/16"
		OS - stainless steel	8	5-59/64"	2-11/16"
1-1/2"	15070FXF	OC - carbon steel	10	7-11/16"	3-15/32"
		OS - stainless steel	10		
		AL - aluminum	3	6-1/8"	3"
2"	270FXF	OC - carbon steel	15	7-17/32"	3-1/4"
		OS - stainless steel	15		
		AL - aluminum	8	6-11/16"	2-7/8"
		BR - brass	16		
MI - ductile iron	14				
3"	370FXF	OC - carbon steel	25	10-1/8"	4-13/16"
		OS - stainless steel	25		
		AL - aluminum	10	8-1/4"	3-7/8"
4"	470FXF	OC - carbon steel	72	14"	6-3/8"
		AL - aluminum	17	10-5/8"	4-3/4"

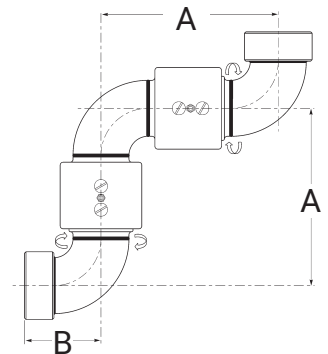

O-Ring Style 70 - 150# Flange x 150# Flange

Size	Part #	Material	Weight (lbs)	Dimensions	
				A	B
1"	170FGXFG	OC - carbon steel	11	4-59/64"	3-3/16"
		OS - stainless steel	11	5-59/64"	
1-1/2"	1570FGFG	OC - carbon steel	14	7-11/16"	4-11/16"
		OS - stainless steel	14		
		AL - aluminum	6	6-1/8"	5-11/32"
2"	270FGXFG	OC - carbon steel	23	7-17/32"	4-1/2"
		OS - stainless steel	23		
		AL - aluminum	12	6-11/16"	5-9/32"
3"	370FGXFG	OC - carbon steel	41	10-1/8"	5-3/4"
		OS - stainless steel	41		
		AL - aluminum	18	8-1/4"	6-15/32"
4"	470FGXFG	OC - carbon steel	88	14"	7"
		AL - aluminum	27	15-5/16"	

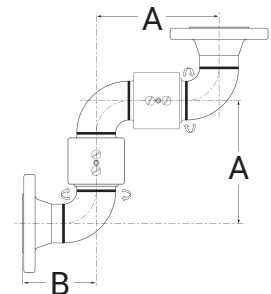

O-Ring Style 80 - FNPT x FNPT

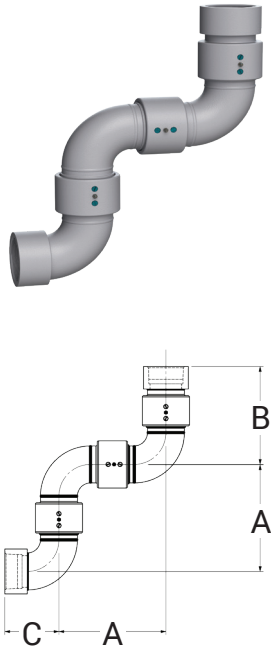

Size	Part #	Material	Weight (lbs)	Dimensions		
				A	B	C
1"	180FXF	OC - carbon steel	9	4-29/32"	5-3/32"	2-3/16"
		OS - stainless steel	9			
1-1/2"	15080FXF	OC - carbon steel	14	6-3/16"	6-1/4"	3-1/16"
		OS - stainless steel	14			
		AL - aluminum	6			
2"	280FXF	OC - carbon steel	19	7-17/32"	7-7/32"	3-11/16"
		OS - stainless steel	19			
		AL - aluminum	10			
3"	380FXF	OC - carbon steel	36	10-1/8"	9-1/4"	5-1/8"
		OS - stainless steel	36			
		AL - aluminum	17			
4"	480FXF	OC - carbon steel	88	14"	12-3/8"	6-3/8"
		AL - aluminum	29			

O-Ring Style 80 - 150# Flange x 150# Flange

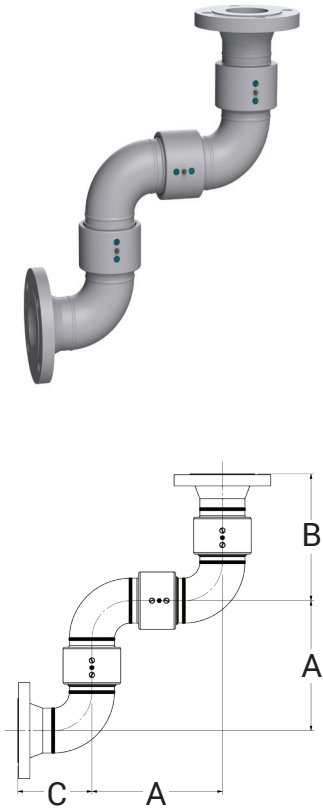

Size	Part #	Material	Weight (lbs)	Dimensions		
				A	B	C
1"	180FGXFG	OC - carbon steel	12	5"	6"	3-13/64"
		OS - stainless steel	13			
1-1/2"	1580FGXFG	OC - carbon steel	19	6-13-64"	7-1/8"	4"
		OS - stainless steel	19			
		AL - aluminum	7			
2"	280FGXFG	OC - carbon steel	28	7-1/2"	8"	4-1/2"
		OS - stainless steel	28			
		AL - aluminum	13			
3"	380FGXFG	OC - carbon steel	51	10-1/8"	9-7/8"	5-3/4"
		OS - stainless steel	51			
		AL - aluminum	22			
4"	480FGXFG	OC - carbon steel	109	14"	13"	7"
		AL - aluminum	37			

O-Ring Style 10 - FNPT x FNPT

Size	Part #	Material	Weight (lbs)	Dimensions	
				A	B
1"	110FXF	OC - carbon steel	9	5"	5"
		OS - stainless steel	9		
1-1/2"	15010FXF	OC - carbon steel	13	6-13/64"	6-1/4"
		OS - stainless steel	13		
		AL - aluminum	5		
2"	210FXF	OC - carbon steel	18	7-1/2"	7-15/64"
		OS - stainless steel	19		
		AL - aluminum	10		
3"	310FXF	OC - carbon steel	33	10-1/8"	9-1/4"
		OS - stainless steel	33		
		AL - aluminum	18		
4"	410FXF	OC - carbon steel	82	14"	12-3/8"
		OS - stainless steel	82		
		AL - aluminum	32		

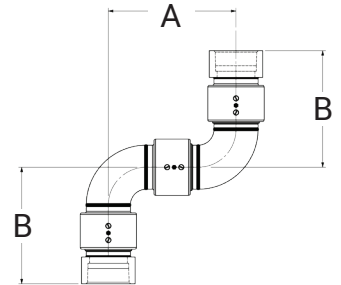

O-Ring Style 10 - 150# Flange x 150# Flange

Size	Part #	Material	Weight (lbs)	Dimensions	
				A	B
1"	110FGXFG	OC - carbon steel	13	5"	6"
		OS - stainless steel	13		
1-1/2"	1510FGFG	OC - carbon steel	18	6-13/64"	7-1/8"
		OS - stainless steel	18		
		AL - aluminum	7		
2"	210FGXFG	OC - carbon steel	27	7-1/2"	8"
		OS - stainless steel	27		
		AL - aluminum	11		
3"	310FGXFG	OC - carbon steel	49	10-1/8"	9-7/8"
		OS - stainless steel	48		
		AL - aluminum	17		
4"	410FGXFG	OC - carbon steel	104	14"	13"
		AL - aluminum	29		

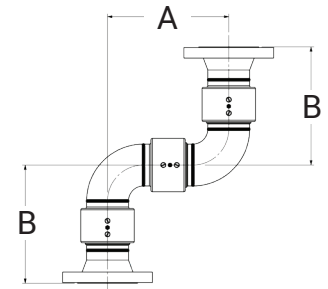

Optional Seals for O-Ring Swivels

O-Ring - Seal Materials

- Materials: Nitrile rubber, FKM, spring-loaded PTFE, food grade nitrile rubber, and EPDM seals

Rebuild Kits for O-Ring Swivels

Each kit contains:

- 1 O-ring (pressure seal) in the material indicated
- 1 O-ring (dust seal) in the material indicated
- 2 ball retainer screws
- 1 grease plug
- 10 ball bearings

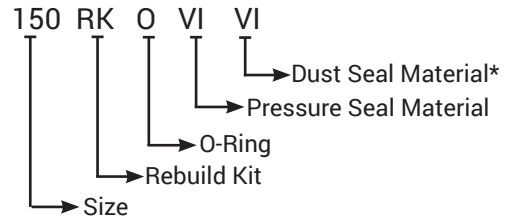

NOTE: All rebuild kits are per plane of rotation
Different grade of ball bearing materials available upon request

Size	Nitrile rubber	FKM/Nitrile rubber	FKM/FKM	PTFE/FKM
1"	1RKOBUB	1RKOVIB	1RKOVIVB	1RKOTFVIB
1-1/4" and 1-1/2"	150RKOBUB	150RKOVIB	150RKOVIVB	150RKOTFVIB
2"	2RKOBUB	2RKOVIB	2RKOVIVB	2RKOTFVIB
3"	3RKOBUB	3RKOVIB	3RKOVIVB	3RKOTFVIB
4"	4RKOBUB	4RKOVIB	4RKOVIVB	---

Total Rebuild Kits for O-Ring Swivels

Each kit contains:

- 1 O-ring (pressure seal) in the material indicated
- 1 O-ring (dust seal) in the material indicated
- 2 ball retainer screws
- 1 grease plug
- Number of ball bearings varies depending on size

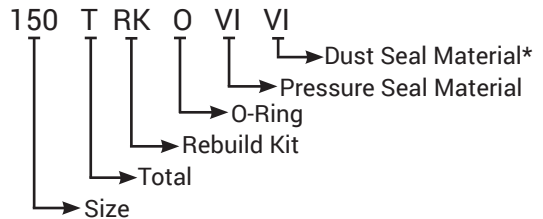

NOTE: All rebuild kits are per plane of rotation
Different grade of ball bearing materials available upon request

Size	Nitrile rubber	FKM/Nitrile rubber	FKM/FKM	PTFE/FKM
1"	1TRKOBUB	1TRKOVIB	1TRKOVIVB	1TRKOTFVIB
1-1/4" and 1-1/2"	150TRKOBUB	150TRKOVIB	150TRKOVIVB	150TRKOTFVIB
2"	2TRKOBUB	2TRKOVIB	2TRKOVIVB	2TRKOTFVIB
3"	3TRKOBUB	3TRKOVIB	3TRKOVIVB	3TRKOTFVIB
4"	4TRKOBUB	4TRKOVIB	4TRKOVIVB	---

Replacement Ball Bearings for O-Ring Swivels

Size	Quantity Per Plane of Rotation	Carbon Steel (standard) Part #	440 Stainless Steel Part #	316 Stainless Steel Part #
1"	40	14CSBA	14SSBA	14SSBA-316
1-1/4" and 1-1/2"	56	14CSBA	14SSBA	14SSBA-316
2"	46	38CSBA	38SSBA	38SSBA-316
3"	62	38CSBA	38SSBA	38SSBA-316
4"	80	38CSBA	38SSBA	38SSBA-316

*If the part number does not include characters for the dust seal, the kit will include a nitrile rubber dust seal.



O-Ring Swivel Seal Replacement Procedure

NOTE: Instructions are not for assembly with spring-loaded PTFE pressure seal, consult Dixon®.

1 Remove the ball retainer screws. Add a sufficient amount of solvent into each raceway to flush out the lubricant. Rotate the sleeve, catching the balls as they fall out. When all the balls have been removed, the body and sleeve can be separated. Discard old seals. Thoroughly clean the body and sleeve.

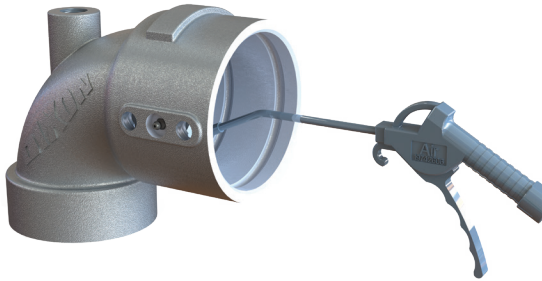

4 Insert the sleeve into the body, slowly rotate the sleeve while inserting into the body.

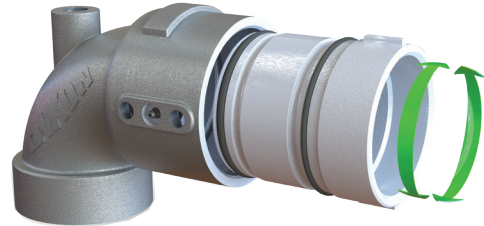

2 Install the new O-rings on the sleeve, dust seal to the rear, product (pressure) seal up front.

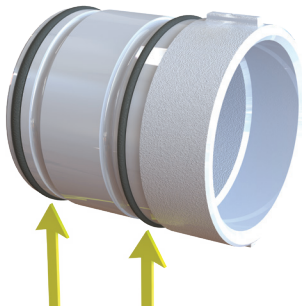

5 When the sleeve is fully inserted, feed the ball bearings into the raceways while rotating the sleeve. To make space for all the balls, insert a screw driver into the raceway, while continuing to rotate the sleeve in one direction (be careful not to damage the threads). This will cause the balls to jam up, making room for the remaining balls. Now reverse rotation of sleeve and insert the remaining balls.

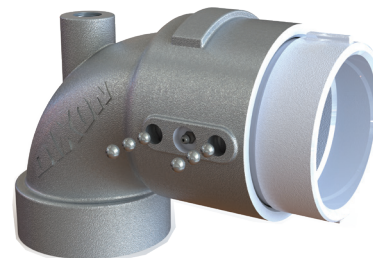

3 Lubricate the body and the sleeve with grease.

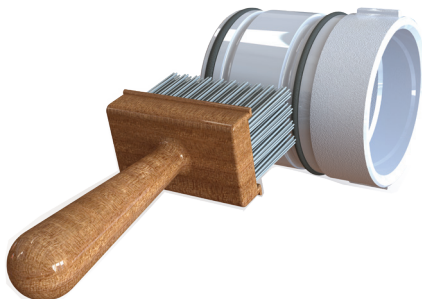

6 Reinstall ball retainer screws until tight. If this interferes with the smooth rotation of the ball bearings, then back off 1/8 - 1/4 turn. A thread locking sealant is recommended to prevent screws from backing off. After pressure testing, the unit is ready for installation.

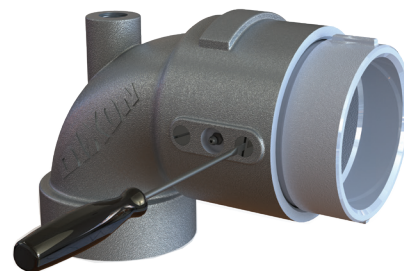

! Body and sleeve are matched during manufacturing. Do not mix components with other units.

Visit Dixon's YouTube channel for more information [youtube.com/@DixonValve](https://www.youtube.com/@DixonValve)

V-Ring Swivel Joints

Applications

- Commonly used in the steel industry, marine bulk transfer, waste water treatment plants, and petrochemical industry.

Sizes

- 2" - 14"

Features

- V-ring, also known as chevron packing, is a multiple lip seal known for its reliability and long life.
- The three V-ring seals are designed to seal even under misalignment caused by race wear from years of service. This design results in longer time between service periods, increased up-time efficiencies, and lower maintenance costs.
- Spring-loaded triple V-ring sealing system ensures a leak-proof seal at high or low pressure and extends seal life
- Swivels are shipped standard with the following:
 - Nitrile rubber pressure seals and dust seals
 - Carbon steel ball bearings
 - PTFE retainers
- Available working pressure ratings up to **1,000 PSI**
- End connections and materials offered may vary based on size, contact Dixon® for details

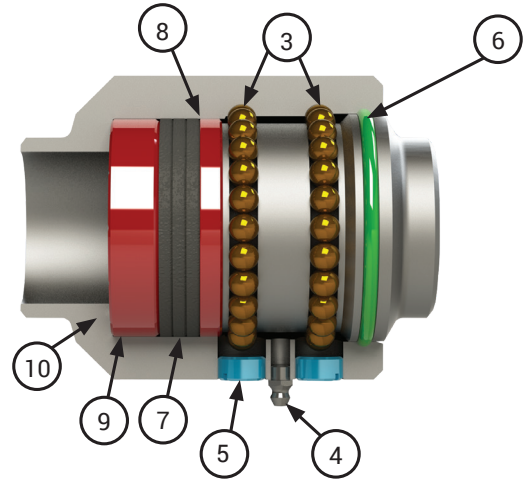

Materials

- Available materials include carbon steel, 316L stainless steel, and aluminum

Bill of Materials

1. Body
2. Sleeve
3. Ball bearings
4. Grease fitting
5. Ball retainer screws
6. O-ring (dust seal)
7. V-ring (pressure seal)
8. Seal retainer
9. Spring retainer
10. Springs

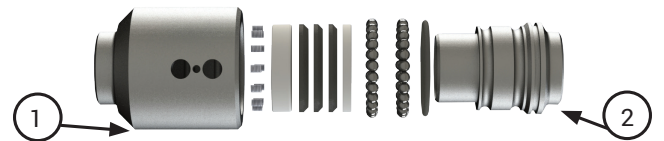

V-Ring Swivel Joint Numbering System

2	20	F	x	F	CS	0	0	2	0	0
Sizes Inches	Style	End Connection	x	End Connection	Material	Pressure Seal	Dust Seal	Retainers	Ball Bearings	Grease
2 = 2"	20	F (FNPT)	x	F (FNPT)	AL = Aluminum	0 = nitrile rubber	0 = nitrile rubber	2 = PTFE retainers	0 = CS carbon steel	0 = lithium
3 = 3"	30	W (weld)	x	W (weld)	CS = V-ring carbon steel	1 = FKM	1 = FKM		1 = 440 stainless steel	1 = food grade
4 = 4"	40	FG (150#)	x	FG (150#)	SS = V-ring 316L stainless steel	2 = PTFE			2 = 316 stainless steel	2 = silicone
6 = 6"	50	PF (300#)	x	PF (300#)		3 = EPDM	3 = EPDM			3 = Tribolube
8 = 8"	60	TF (TTMA)	x	TF (TTMA)		4 = FDA nitrile rubber	4 = FDA nitrile rubber			4 = low temperature
10 = 10"	70	BP (BSPP)	x	BP (BSPP)		5 = No seal	5 = No seal			5 = no grease
12 = 12"	80	BT (BSPT)	x	BT (BSPT)						
14 = 14"	10	G (groove)	x	G (groove)						
		M (MNPT)	x	M (MNPT)						

NOTE: Other end connections or seals are available upon request.

- Standard grease fitting without ball check. Ask for ball check if required.
- Aluminum V-ring version only available in 6" and 8"

V-Ring Style 20 - Weld x Weld

Size	Part #	Material	Weight (lbs)	Dimension A
2"	220WXW	CS - carbon steel	9	5-5/16"
		SS - stainless steel	9	
3"	320WXW	CS - carbon steel	13	5-3/4"
		SS - stainless steel	13	
4"	420WXW	CS - carbon steel	24	7"
		SS - stainless steel	25	
6"	620WXW	CS - carbon steel	55	8-3/8"
		SS - stainless steel	57	
		AL - aluminum	22	
8"	820WXW	CS - carbon steel	78	8-5/8"
		SS - stainless steel	92	
		AL - aluminum	35	
10"	1020WXW	CS - carbon steel	190	11-5/8"
		SS - stainless steel	193	
12"	1220WXW	CS - carbon steel	208	11-11/32"
		SS - stainless steel	211	
14"	1420WXW	CS - carbon steel	246	11-3/4"

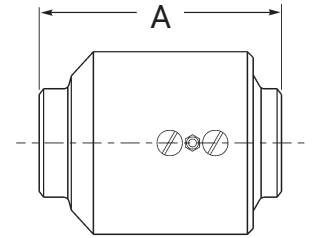
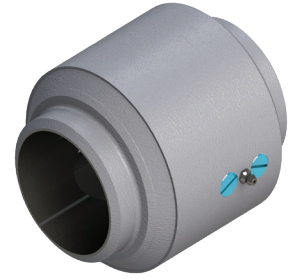

V-Ring Style 20 - FNPT x FNPT

Size	Part #	Material	Weight (lbs)	Dimension A
2"	220FXF	CS - carbon steel	13	8-11/16"
		SS - stainless steel	12	
3"	320FXF	CS - carbon steel	17	10"
		SS - stainless steel	18	
4"	420FXF	CS - carbon steel	37	11-3/4"
		SS - stainless steel	38	
6"	620FXF	CS - carbon steel	68	12-1/8"
		SS - stainless steel	70	
		AL - aluminum	26	

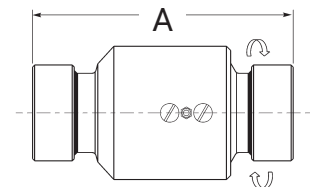
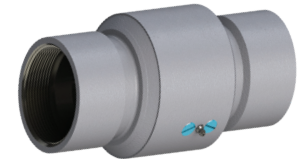

V-Ring Style 20 - 150# Flange x 150# Flange

Size	Part #	Material	Weight (lbs)	Dimension A
2"	220FGXFG	CS - carbon steel	22	10-5/16"
		SS - stainless steel	21	
3"	320FGXFG	CS - carbon steel	36	11-1/4"
		SS - stainless steel	35	
4"	420FGXFG	CS - carbon steel	57	13"
		SS - stainless steel	58	
6"	620FGXFG	CS - carbon steel	104	15-3/8"
		SS - stainless steel	106	
		AL - aluminum	39	
8"	820FGXFG	CS - carbon steel	162	16-5/8"
		SS - stainless steel	170	
		AL - aluminum	61	
10"	1020FGFG	CS - carbon steel	296	19-5/8"
		SS - stainless steel	300	
12"	1220FGFG	CS - carbon steel	369	20-11/32"
		SS - stainless steel	374	
14"	1420FGFG	CS - carbon steel	Contact factory for weights and dimensions	

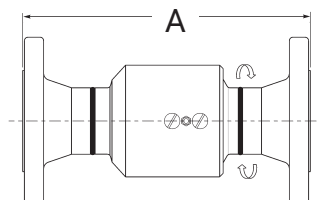
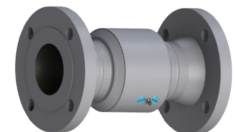

V-Ring Style 30 - FNPT x FNPT



Size	Part #	Material	Weight (lbs)	Dimensions	
				A	B
2"	230FXF	CS - carbon steel	12	9"	3-11/16"
		SS - stainless steel	12		
3"	330FXF	CS - carbon steel	21	10-7/8"	5-1/8"
		SS - stainless steel	21		
4"	430FXF	CS - carbon steel	42	13-3/8"	6-3/8"
		SS - stainless steel	44		
6"	630FXF	CS - carbon steel	84	16-1/4"	7-7/8"
		SS - stainless steel	84		
		AL - aluminum	32		

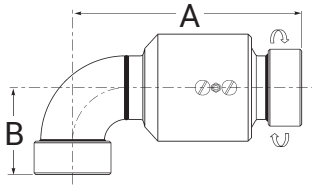

V-Ring Style 30 - 150# Flange x 150# Flange



Size	Part #	Material	Weight (lbs)	Dimensions	
				A	B
2"	230FGXFG	CS - carbon steel	23	9-13/16"	4-1/2"
		SS - stainless steel	22		
3"	330FGXFG	CS - carbon steel	39	11-1/2"	5-3/4"
		SS - stainless steel	38		
4"	430FGXFG	CS - carbon steel	64	14"	7"
		SS - stainless steel	65		
6"	630FGXFG	CS - carbon steel	121	17-7/8"	9-1/2"
		SS - stainless steel	121		
		AL - aluminum	45		
8"	830FGXFG	CS - carbon steel	196	20-5/8"	12"
		SS - stainless steel	208		
		AL - aluminum	77		
10"	1030FGFG	CS - carbon steel	343	25-27/32"	14"
		SS - stainless steel	347		
12"	1230FGFG	CS - carbon steel	451	27-27/32"	16-1/2"
		SS - stainless steel	457		
14"	1430FGFG	CS - carbon steel	Contact factory for weights and dimensions		

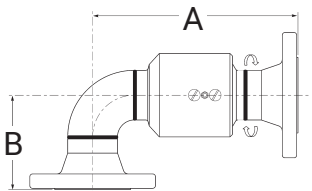

V-Ring Style 40 - FNPT x FNPT

Size	Part #	Material	Weight (lbs)	Dimensions		
				A	B	C
2"	240FXF	CS - carbon steel	13	9-5/16"	3-11/16"	7-3/8"
		SS - stainless steel	13			
3"	340FXF	CS - carbon steel	24	11-3/4"	5-1/8"	10-1/4"
		SS - stainless steel	24			
4"	440FXF	CS - carbon steel	47	15"	6-3/8"	12-3/4"
		SS - stainless steel	51			
6"	640FXF	CS - carbon steel	101	20-3/8"	7-7/8"	15-3/4"
		SS - stainless steel	99			
		AL - aluminum	39			

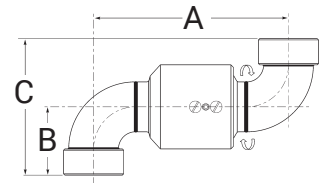

V-Ring Style 40 - 150# Flange x 150# Flange

Size	Part #	Material	Weight (lbs)	Dimensions		
				A	B	C
2"	240FGXFG	CS - carbon steel	24	9-5/16"	4-1/2"	9"
		SS - stainless steel	23			
3"	340FGXFG	CS - carbon steel	49	11-3/4"	5-3/4"	11-1/2"
		SS - stainless steel	41			
4"	440FGXFG	CS - carbon steel	70	15"	7"	14"
		SS - stainless steel	72			
6"	640FGXFG	CS - carbon steel	138	20-3/8"	9-1/2"	19"
		SS - stainless steel	136			
		AL - aluminum	52			
8"	840FGXFG	CS - carbon steel	230	24-5/8"	12"	24"
		SS - stainless steel	246			
		AL - aluminum	92			
10"	1040FGFG	CS - carbon steel	395	31-1/16"	14"	28"
		SS - stainless steel	400			
12"	1240FGFG	CS - carbon steel	533	35-11/32"	16-1/2"	33"
		SS - stainless steel	540			
14"	1440FGFG	CS - carbon steel	Contact factory for weights and dimensions			

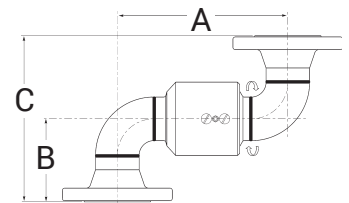

V-Ring Style 50 - FNPT x FNPT

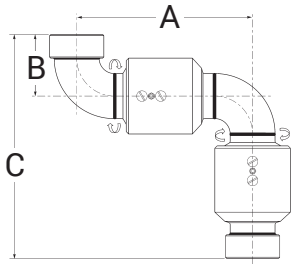

Size	Part #	Material	Weight (lbs)	Dimensions		
				A	B	C
2"	250FXF	CS - carbon steel	23	9-5/16"	3-11/16"	12-11/16"
		SS - stainless steel	23			
3"	350FXF	CS - carbon steel	37	11-3/4"	5-1/8"	16"
		SS - stainless steel	37			
4"	450FXF	CS - carbon steel	73	15"	6-3/8"	19-3/4"
		SS - stainless steel	76			
6"	650FXF	CS - carbon steel	156	20-3/8"	7-7/8"	24-1/8"
		SS - stainless steel	155			
		AL - aluminum	61			

V-Ring Style 50 - 150# Flange x 150# Flange

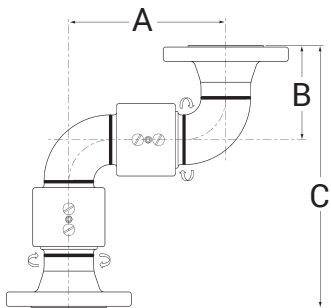

Size	Part #	Material	Weight (lbs)	Dimensions		
				A	B	C
2"	250FGXFG	CS - carbon steel	33	9-5/16"	4-1/2"	14-5/16"
		SS - stainless steel	32			
3"	350FGXFG	CS - carbon steel	56	11-3/4"	5-3/4"	17-1/4"
		SS - stainless steel	54			
4"	450FGXFG	CS - carbon steel	94	15"	7"	21"
		SS - stainless steel	97			
6"	650FGXFG	CS - carbon steel	192	20-3/8"	9-1/2"	27-3/8"
		SS - stainless steel	192			
		AL - aluminum	74			
8"	850FGXFG	CS - carbon steel	309	24-5/8"	12"	32-5/8"
		SS - stainless steel	338			
		AL - aluminum	128			
10"	1050FGFG	CS - carbon steel	585	31-27/32"	14"	39-5/8"
		SS - stainless steel	592			
12"	1250FGFG	CS - carbon steel	741	35-11/32"	16-1/2"	44-11/32"
		SS - stainless steel	751			
14"	1450FGFG	CS - carbon steel	Contact factory for weights and dimensions			

V-Ring Style 60 - FNPT x FNPT

Size	Part #	Material	Weight (lbs)	Dimension A
2"	260FXF	CS - carbon steel	22	9"
		SS - stainless steel	22	
3"	360FXF	CS - carbon steel	34	10-7/8"
		SS - stainless steel	34	
4"	460FXF	CS - carbon steel	72	13-3/8"
		SS - stainless steel	72	
6"	660FXF	CS - carbon steel	118	16-1/4"
		SS - stainless steel	140	
		AL - aluminum	56	

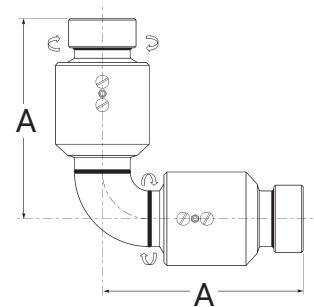
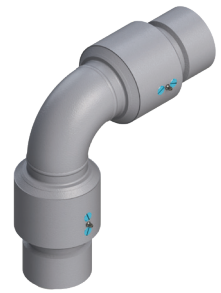

V-Ring Style 60 - 150# Flange x 150# Flange

Size	Part #	Material	Weight (lbs)	Dimension A
2"	260FGXFG	CS - carbon steel	42	9-13/16"
		SS - stainless steel	42	
3"	360FGXFG	CS - carbon steel	83	11-1/2"
		SS - stainless steel	83	
4"	460FGXFG	CS - carbon steel	106	14"
		SS - stainless steel	106	
6"	660FGXFG	CS - carbon steel	172	17-7/8"
		SS - stainless steel	172	
		AL - aluminum	69	
8"	860FGXFG	CS - carbon steel	312	20-5/8"
		SS - stainless steel	312	
		AL - aluminum	117	
10"	1060FGFG	CS - carbon steel	535	25-27/32"
		SS - stainless steel	542	
12"	1260FGFG	CS - carbon steel	660	27-27/32"
		SS - stainless steel	668	
14"	1460FGFG	CS - carbon steel	Contact factory for weights and dimensions	

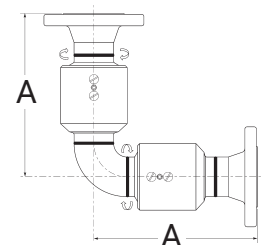

V-Ring Style 70 - FNPT x FNPT

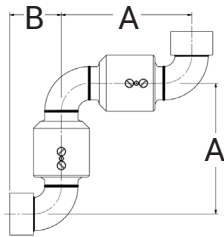

Size	Part #	Material	Weight (lbs)	Dimensions	
				A	B
2"	270FXF	CS - carbon steel	24	9-5/16"	3-11/16"
		SS - stainless steel	24		
3"	370FXF	CS - carbon steel	42	11-3/4"	5-1/8"
		SS - stainless steel	42		
4"	470FXF	CS - carbon steel	79	15"	6-3/8"
		SS - stainless steel	79		
6"	670FXF	CS - carbon steel	168	20-3/8"	7-7/8"
		SS - stainless steel	168		
		AL - aluminum	64		

V-Ring Style 70 - 150# Flange x 150# Flange

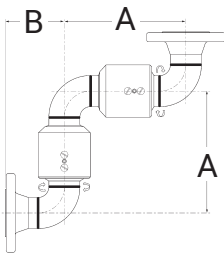

Size	Part #	Material	Weight (lbs)	Dimensions	
				A	B
2"	270FGXFG	CS - carbon steel	34	9-5/16"	4-1/2"
		SS - stainless steel	33		
3"	370FGXFG	CS - carbon steel	59	11-3/4"	5-3/4"
		SS - stainless steel	57		
4"	470FGXFG	CS - carbon steel	100	15"	7"
		SS - stainless steel	103		
6"	670FGXFG	CS - carbon steel	209	20-3/8"	9-1/2"
		SS - stainless steel	207		
		AL - aluminum	82		
8"	870FGXFG	CS - carbon steel	343	24-5/8"	12"
		SS - stainless steel	376		
		AL - aluminum	143		
10"	1070FGFG	CS - carbon steel	637	31-27/32"	14"
		SS - stainless steel	645		
12"	1270FGFG	CS - carbon steel	823	35-11/32"	16-1/2"
		SS - stainless steel	834		
14"	1470FGFG	CS - carbon steel	Contact factory for weights and dimensions		

V-Ring Style 80 - FNPT x FNPT

Size	Part #	Material	Weight (lbs)	Dimensions		
				A	B	C
2"	280FXF	CS - carbon steel	33	9-5/16"	9-9/16"	3-11/16"
		SS - stainless steel	34			
3"	380FXF	CS - carbon steel	53	11-3/4"	10-7/8"	5-1/8"
		SS - stainless steel	53			
4"	480FXF	CS - carbon steel	104	15"	13-3/8"	6-3/8"
		SS - stainless steel	108			
6"	680FXF	CS - carbon steel	227	20-3/8"	16-1/4"	7-7/8"
		SS - stainless steel	227			
		AL - aluminum	89			

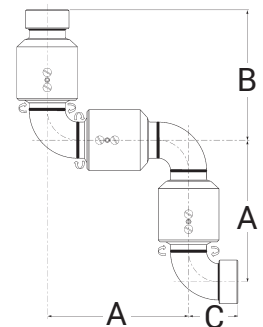

V-Ring Style 80 - 150# Flange x 150# Flange

Size	Part #	Material	Weight (lbs)	Dimensions		
				A	B	C
2"	280FGXFG	CS - carbon steel	43	9-5/16"	9-13/16"	4-1/2"
		SS - stainless steel	42			
3"	380FGXFG	CS - carbon steel	72	11-3/4"	11-1/2"	5-3/4"
		SS - stainless steel	70			
4"	480FGXFG	CS - carbon steel	125	15"	14"	7"
		SS - stainless steel	128			
6"	680FGXFG	CS - carbon steel	264	20-3/8"	17-7/8"	9-1/2"
		SS - stainless steel	263			
		AL - aluminum	102			
8"	880FGXFG	CS - carbon steel	421	24-5/8"	20-5/8"	12"
		SS - stainless steel	468			
		AL - aluminum	178			
10"	1080FGFG	CS - carbon steel	827	31-19/32"	25-19/32"	14"
		SS - stainless steel	838			
12"	1280FGFG	CS - carbon steel	1032	35-11/32"	27-27/32"	16-1/2"
		SS - stainless steel	1045			
14"	1480FGFG	CS - carbon steel	Contact factory for weights and dimensions			

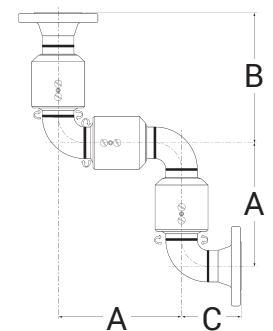

V-Ring Style 10 - FNPT x FNPT

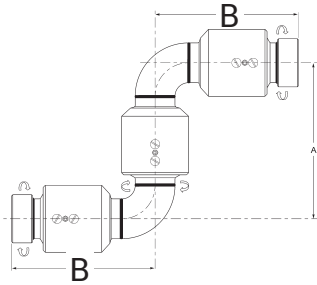

Size	Part #	Material	Weight (lbs)	Dimensions	
				A	B
2"	210FXF	CS - carbon steel	32	9-5/16"	9"
		SS - stainless steel	33		
3"	310FXF	CS - carbon steel	50	11-3/4"	10-7/8"
		SS - stainless steel	50		
4"	410FXF	CS - carbon steel	97	15"	13-3/8"
		SS - stainless steel	101		
6"	610FXF	CS - carbon steel	210	20-3/8"	16-1/4"
		SS - stainless steel	200		
		AL - aluminum	69		

V-Ring Style 10 - 150# Flange x 150# Flange

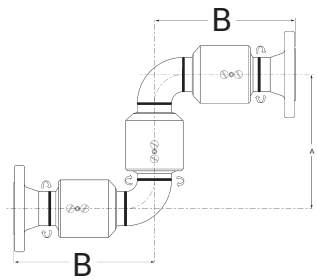

Size	Part #	Material	Weight (lbs)	Dimensions	
				A	B
2"	210FGXFG	CS - carbon steel	42	9-5/16"	9-13/16"
		SS - stainless steel	41		
3"	310FGXFG	CS - carbon steel	69	11-3/4"	11-1/2"
		SS - stainless steel	67		
4"	410FGXFG	CS - carbon steel	119	15"	14"
		SS - stainless steel	122		
6"	610FGXFG	CS - carbon steel	222	20-3/8"	17-7/8"
		SS - stainless steel	234		
		AL - aluminum	97		
8"	810FGXFG	CS - carbon steel	387	24-5/8"	20-5/8"
		SS - stainless steel	430		
		AL - aluminum	163		
10"	1010FGFG	CS - carbon steel	775	31-1/16"	25-27/32"
		SS - stainless steel	785		
12"	1210FGFG	CS - carbon steel	950	35-11/32"	27-27/32"
		SS - stainless steel	962		
14"	1410FGFG	CS - carbon steel	Contact factory for weights and dimensions		

Repair Parts For V-Ring Swivels

V-Ring - Seal Material

- Materials: Nitrile rubber, FKM, PTFE, food grade nitrile rubber, and EPDM seals

Rebuild Kits for V-Ring Swivels

Each kit contains:

- 3 V-ring (pressure seal) in the material indicated
- 1 dust seal in the material indicated
- 2 ball retainer screws
- 1 grease plug
- 10 ball bearings

NOTE: All rebuild kits are per plane of rotation
Different grade of ball bearing materials available upon request

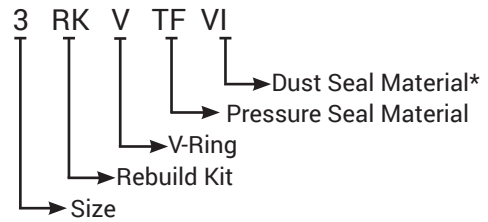

Size	Nitrile rubber	FKM/Nitrile rubber	FKM/FKM	PTFE/FKM
2"	2RKVBV	2RKVVI	2RKVVIVI	2RKVTFVI
3"	3RKVBV	3RKVVI	3RKVVIVI	3RKVTFVI
4"	4RKVBV	4RKVVI	4RKVVIVI	4RKVTFVI
6"	6RKVBV	6RKVVI	6RKVVIVI	6RKVTFVI
8"	8RKVBV	8RKVVI	8RKVVIVI	8RKVTFVI
10"	10RKVBV	10RKVVI	10RKVVIVI	10RKVTFVI
12"	12RKVBV	12RKVVI	12RKVVIVI	12RKVTFVI

Total Rebuild Kits for V-Ring Swivels

Each kit contains:

- 3 V-ring (pressure seal) in the material indicated
- 1 dust seal in the material indicated
- 2 ball retainer screws
- Number of grease plugs varies depending on size
- 2 PTFE retainers
- Number of ball bearings varies depending on size

NOTE: All rebuild kits are per plane of rotation
Different grade of ball bearing materials available upon request

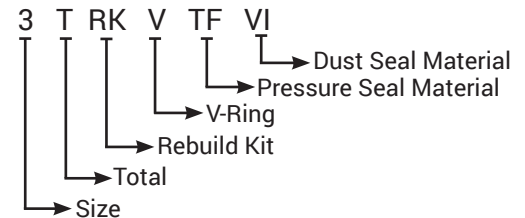

Size	Nitrile rubber	FKM/Nitrile rubber	FKM/FKM	PTFE/FKM
2"	2TRKBU	2TRKVI	2TRKVIVI	2TRKTFVI
3"	3TRKBU	3TRKVI	3TRKVIVI	3TRKTFVI
4"	4TRKBU	4TRKVI	4TRKVIVI	4TRKTFVI
6"	6TRKBU	6TRKVI	6TRKVIVI	6TRKTFVI
8"	8TRKBU	8TRKVI	8TRKVIVI	8TRKTFVI

Replacement Ball Bearings for V-Ring Swivels

- Materials: carbon steel, 440 stainless steel or 316 stainless steel

Size	Quantity Per Plane of Rotation	Carbon Steel (standard) Part #	440 Stainless Steel Part #	316 Stainless Steel Part #
2"	48	38CSBA	38SSBA	38SSBA-316
3"	66	38CSBA	38SSBA	38SSBA-316
4"	86	38CSBA	38SSBA	38SSBA-316
6"	98	12CSBA	12SSBA	12SSBA-316
8"	80	34CSBA	34SSBA	34SSBA-316
10"	82	1CSBA	1SSBA	1SSBA-316
12"	86	1CSBA	1SSBA	1SSBA-316
14"	96	1CSBA	1SSBA	1SSBA-316

*If the part number does not include characters for the dust seal, the kit will include a nitrile rubber dust seal.



V-Ring Swivel Seal Replacement Procedure

1 Remove the ball retainer screws. Add a sufficient amount of solvent into each raceway to flush out the lubricant. Rotate the sleeve, catching the balls as they fall out. When all the balls have been removed, the body and sleeve can be separated. Discard old seals. Thoroughly clean the body, sleeve retainer, spring retainer, and springs.



2 Lubricate the body unit with a Moly lubricant or equivalent.



3 Place the assembled spring retainer unit (spring end first) into the body*. Place the set of V-rings onto the spring retainer. Be sure V-rings are installed with the sealing lips facing toward the retainer. Lubricate the body and seals with a moly lubricant or equivalent.

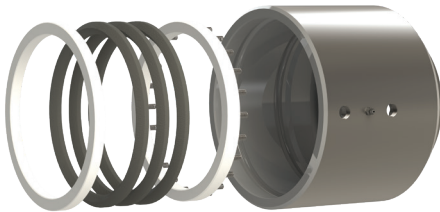

4 Set the dust seal into O-ring groove on the sleeve. Place the seal retainer on the sleeve with the grooved end facing the V-rings. Lubricate the sleeve with grease.

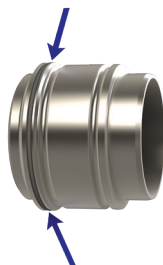

Visit Dixon's YouTube channel for more information [youtube.com/@DixonValve](https://www.youtube.com/@DixonValve)

5 Insert sleeve into body, compressing swivel joint together until ball races or body and sleeve are in alignment (do not rotate either unit while compressing). Care should be taken to avoid pinching or scoring of V-rings. Drop balls into raceway holes, rotating the sleeve slowly as you load. To make space for all the balls, insert a screw driver into the raceway while continuing to rotate the sleeve in one direction (be careful not to damage the threads). This will cause the balls to jam up, making room for the remaining balls. Now reverse the rotation of the sleeve and insert the remaining balls.

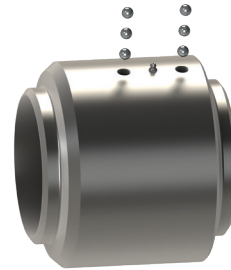

6 Reinstall ball retainer screws until tight. If this interferes with the smooth rotation of the ball bearings, then back off 1/8 - 1/4 turn. A thread locking sealant is recommended to prevent screws from backing off. After pressure testing, the unit is ready for installation.

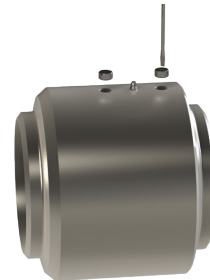

* The last coil of the springs has been upset (O.D. slightly larger). When upset end is inserted into the holes provided in the spring retainer, the springs remain secure.



Body and sleeve are matched during manufacturing. Do not mix components with other units.

Cap Seal Swivel Joints

Applications

- Liquid media transfer lines in steel-making plants, floating roof drains, and floating suction systems



Sizes

- 14" – 24"

Features

- Pressure seal consists of a nitrile or FKM energizer with glass Moly filled PTFE outer cap seal allowing for a lower torque requirement to rotate
- Nitrile or FKM X-ring dust seal for additional reduction in required torque to rotate
- Triple ball-race design for 18" and larger
- Hardened ball races for increased load capacities of carbon steel swivels
- Available end connections include 150# and 300# flanges and weld ends. Contact Dixon® for more details

Materials

- Carbon steel and 316L stainless steel

Bill of Materials

1. Body
2. Sleeve
3. Ball bearings (14" - 16" = 2 ball races, 18" - 24" = 3 ball races)
4. Grease fitting
5. Ball retainer screws
6. Dust seal (X-ring)
7. Pressure seal (cap seal)

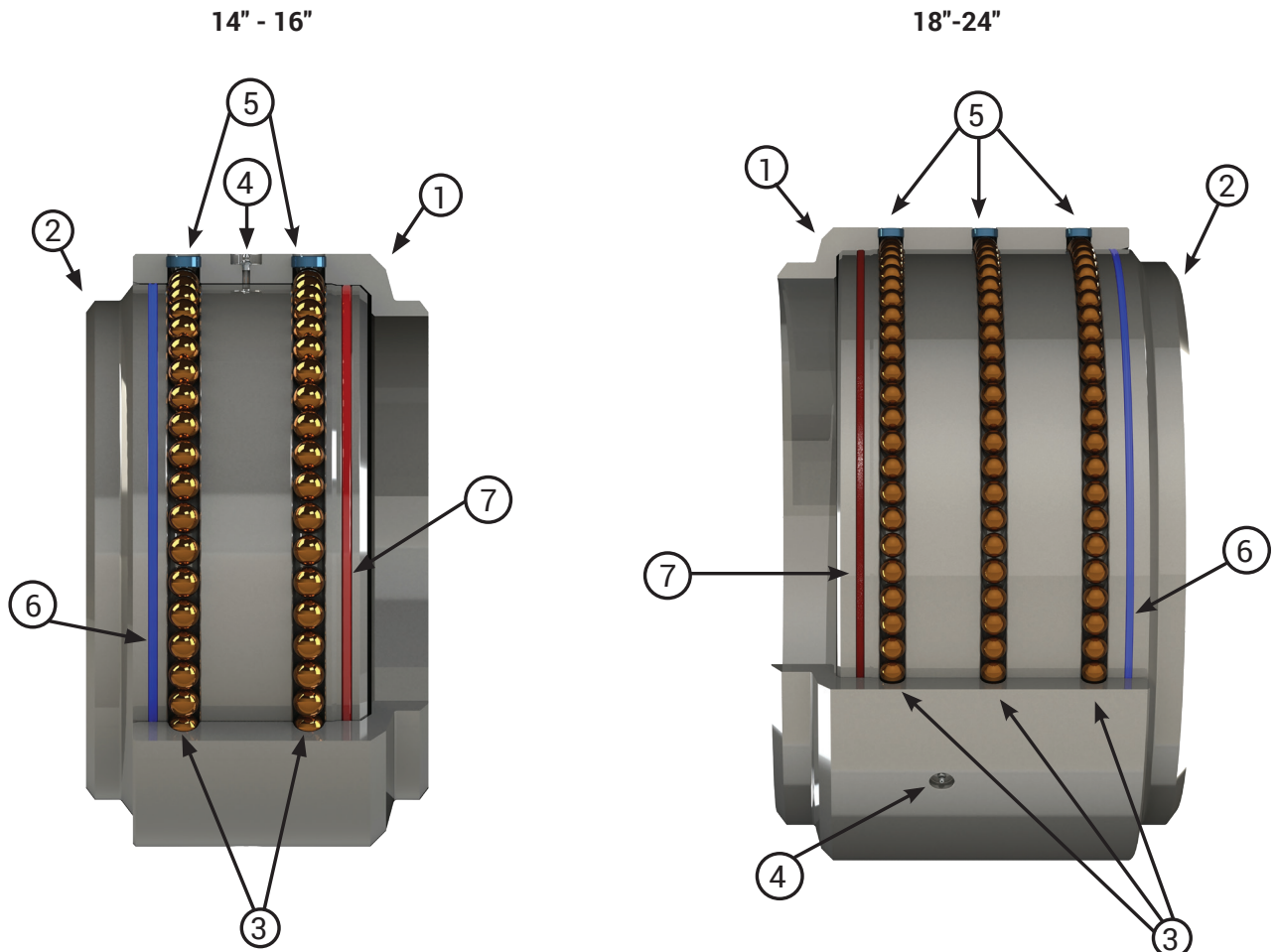

Cap Seal Swivel Joint Numbering System

16	20	FG	FG	UC	0	0	0	0	0
Sizes Inches	Style	End Connection	End Connection	Material	Pressure Seal	Dust Seal	Retainers	Ball Bearings	Grease
14 = 14"	20	W (weld)	W (weld)	UC = Cap Seal Carbon Steel	0 = nitrile rubber	0 = nitrile rubber	0 = No retainer	0 = CS carbon steel	0 = lithium
16 = 16"	30	FG (150#)	FG (150#)	US = Cap Seal 316L Stainless Steel	1 = FKM	1 = FKM		1 = 440 stainless steel	1 = food grade steel
18 = 18"	40	PF (300#)	PF (300#)		5 = No seal	5 = No seal		2 = 316 stainless steel	2 = silicone
20 = 20"	50								3 = Tribolube
24 = 24"	60								4 = low temperature
	70								5 = no grease

NOTE: Other end connections or seals are available upon request.

- Includes standard issue grease fittings without ball check. Ask for ball check if required.

Cap Seal Style 20 - Weld x Weld



Size	Part #	Material	Weight (lbs)	Dimension A
14"	1420WXW	UC - carbon steel	255	11-23/32"
16"	1620WXW	UC - carbon steel	255	10-31/32"
		US - stainless steel	250	
18"	1820WXW	UC - carbon steel	330	12-3/32"
		US - stainless steel	325	
20"	2020WXW	UC - carbon steel	440	14"
24"	2420WXW	UC - carbon steel	660	16-7/8"

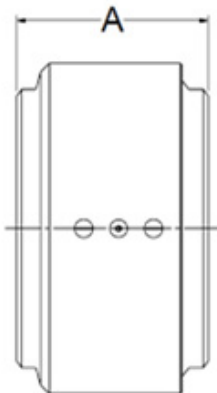

Cap Seal Style 20 - 150# Flange x 150# Flange

Size	Part #	Material	Weight (lbs)	Dimension A
14"	1420FGFG	UC - carbon steel	485	21-25/32"
16"	1620FGFG	UC - carbon steel	545	21"
		US - stainless steel	535	
18"	1820FGFG	UC - carbon steel	670	23-3/32"
		US - stainless steel	660	
20"	2020FGFG	UC - carbon steel	860	25-3/8"
24"	2420FGFG	UC - carbon steel	1255	28-7/8"

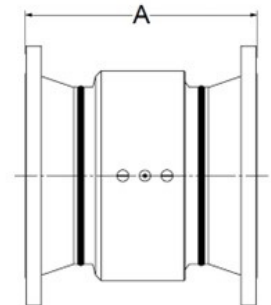
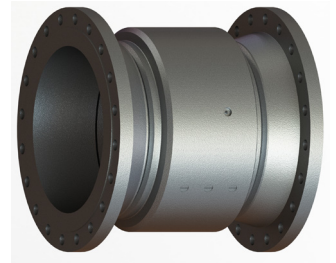

Cap Seal Style 20 - 300# Flange x 300# Flange

Size	Part #	Material	Weight (lbs)	Dimension A
14"	1420PFPF	UC - carbon steel	655	22-31/32"
16"	1620PFPF	UC - carbon steel	755	22-15/32"
		US - stainless steel	745	
18"	1820PFPF	UC - carbon steel	960	24-19/32"
		US - stainless steel	950	
20"	2020PFPF	UC - carbon steel	1205	26-3/4"
24"	2420PFPF	UC - carbon steel	1790	30-1/8"

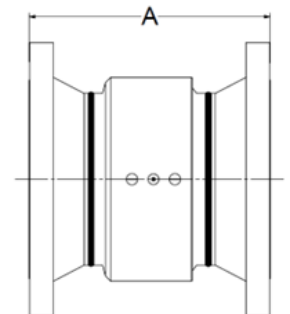
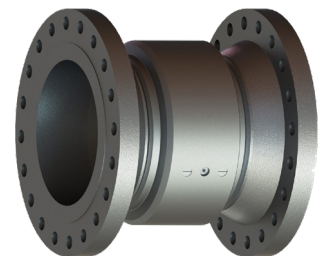

Cap Seal Style 30 - 150# Flange x 150# Flange



Size	Part #	Material	Weight (lbs)	Dimensions	
				A	B
14"	1430FGFG	UC - carbon steel	590	30-23/32"	19"
16"	1630FGFG	UC - carbon steel	680	31-31/32"	21"
		US - stainless steel	670		
18"	1830FGFG	UC - carbon steel	845	35-19/32"	23-1/2"
		US - stainless steel	830		
20"	2030FGFG	UC - carbon steel	1080	39-11/16"	25-11/16"
24"	2430FGFG	UC - carbon steel	1570	46-7/8"	30"

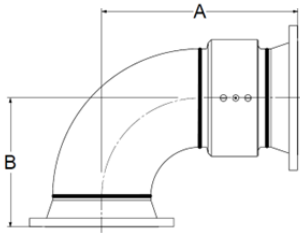

Cap Seal Style 30 - 300# Flange x 300# Flange



Size	Part #	Material	Weight (lbs)	Dimensions	
				A	B
14"	1430PFPF	UC - carbon steel	760	31-11/32"	19-5/8"
16"	1630PFPF	UC - carbon steel	895	32-23/32"	21-3/4"
		US - stainless steel	885		
18"	1830PFPF	UC - carbon steel	1135	36-11/32"	24-1/4"
		US - stainless steel	1120		
20"	2030PFPF	UC - carbon steel	1425	40-3/8"	26-3/8"
24"	2430PFPF	UC - carbon steel	2105	30-5/8"	

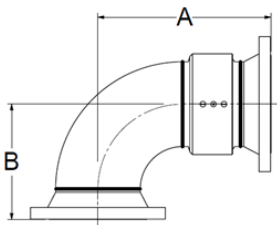

Cap Seal Style 40 - 150# Flange x 150# Flange

Size	Part #	Material	Weight (lbs)	Dimensions		
				A	B	C
14"	1440FGFG	UC - carbon steel	695	39-23/32"	19"	38"
16"	1640FGFG	UC - carbon steel	815	42-31/32"	21"	42"
		US - stainless steel	805			
18"	1840FGFG	UC - carbon steel	1015	48-3/32"	23-1/2"	47"
		US - stainless steel	1005			
20"	2040FGFG	UC - carbon steel	1295	54"	25-11/16"	51-3/8"
24"	2440FGFG	UC - carbon steel	1885	64-7/8"	30"	60"

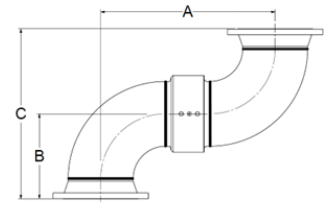

Cap Seal Style 40 - 300# Flange x 300# Flange

Size	Part #	Material	Weight (lbs)	Dimensions		
				A	B	C
14"	1440PFPF	UC - carbon steel	870	39-23/32"	19-5/8"	39-1/4"
16"	1640PFPF	UC - carbon steel	1035	42-31/32"	21-3/4"	43-1/2"
		US - stainless steel	1020			
18"	1840PFPF	UC - carbon steel	1315	48-3/32"	21-1/4"	48-1/2"
		US - stainless steel	1295			
20"	2040PFPF	UC - carbon steel	1645	54"	26-3/8"	52-3/4"
24"	2440PFPF	UC - carbon steel	2425	64-7/8"	30-5/8"	61-1/4"

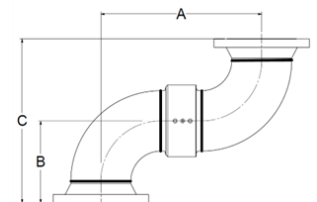

Cap Seal Swivel Joint Seal Replacement Procedure

1 Remove the raceway set screws. Rotate the sleeve inside the body, while removing the ball bearings using a magnetic pick-up tool. When all the balls have been removed, the body and sleeve can be separated.



2 Remove the seals using hand tools that will not damage or scratch the seal grooves. Discard old seals. Thoroughly clean the body, sleeve, and ball bearings using solvent/degreaser.



3 Apply grease to the dust seal groove, which is the one closest to the weld, using a small chip/paint brush.



4 Dry wipe the X-ring (quad) dust seal using a shop towel to remove any debris (refer to seal guide). Put the dust seal into the dust seal groove of the swivel sleeve. Inspect the dust seal to make sure there are no twists.



5 Apply grease to the dust seal and the outside of the swivel sleeve on all surfaces extending from the dust seal groove to the pressure seal groove.



6 Install the O-ring energizer into the pressure seal groove (Refer to Seal Guide). Inspect the O-ring energizer to make sure it is not twisted and apply grease to the O-ring energizer.



Cap Seal Swivel Joint Seal Replacement Procedure

7 Install the cap pressure seal over top of the pressure seal energizer (Refer to seal guide). The small groove faces outward. Metal or sharp tools must not be used to install the cap seal. Apply grease to the cap pressure seal.



8 Apply grease to the inside of the swivel body on all surfaces extending from the dust seal sealing face to the pressure seal sealing face.

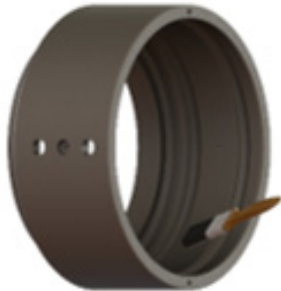

9 Move the swivel sleeve (or move the swivel body) so that the sleeve and body are concentrically aligned.



10 Insert the swivel sleeve into the body until the raceways are aligned.



11 Insert the ball bearings into the raceways while rotating one of the components (body or sleeve).

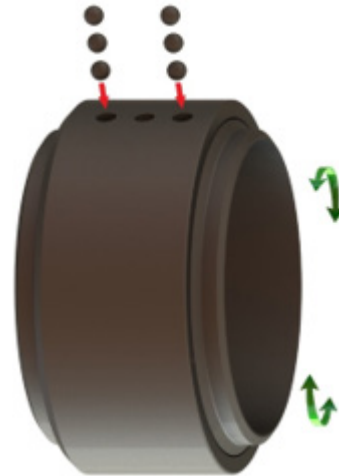

12 Install the set screws and grease plugs. Add grease into the grease plug, as necessary (application dependent).



O-ring Pressure Seal Energizer



Cap Pressure Seal



X-ring Dust Seal



Split Flange Swivel Joints

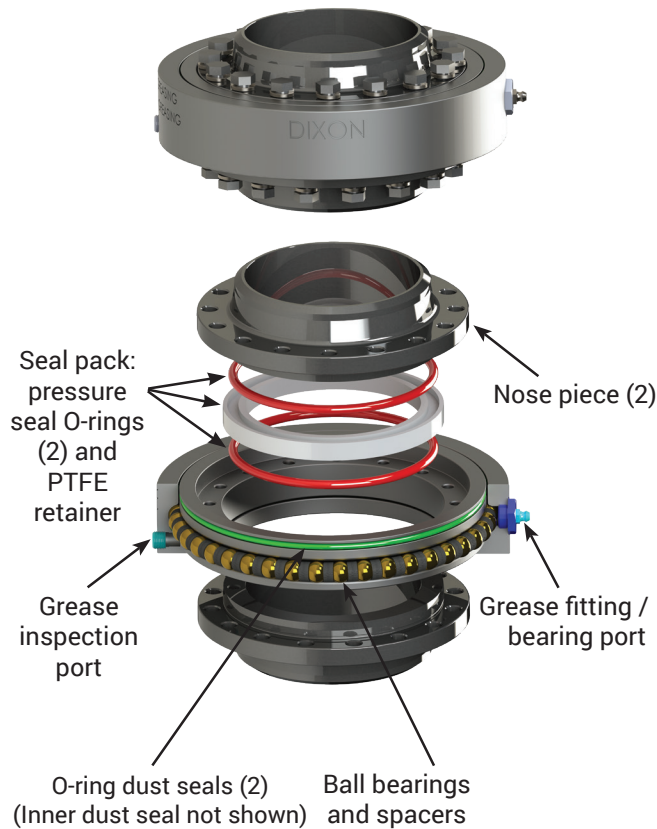

Applications

- For use in industries from petroleum, blending plants, petrochemical, refining, mining, distilling, paint plants, farm irrigation and fertilizing, wastewater treatment, food and beverage process equipment, marine, and many more

Sizes

- 2", 3", and 4"

Features

- Bearing pack design allows easy seal change without removing the ball bearings
- Simple maintenance: remove one nose piece, replace seal pack, and reinstall with little downtime
- In-stream seal separates the wetted area from the ball bearings, allowing for longer bearing pack life compared to conventional swivels
- Single wide-set bearing race for higher moment loads
- Compact design for low-profile applications
- Full penetration weld

Materials

- Bearing pack: through hardened forged high-carbon alloy
- Material contact surfaces: stainless steel, carbon steel, or aluminum nose pieces
- Seals: Baylast™, FKM, PTFE, and more upon request

Specifications

- Pressure rating: up to **600 PSI**
- Standard temperature range with Baylast™ seals is **-30°F to 212°F (-34°C to 100°C)**; contact factory for other temperature requirements

Available options

- Swivel end configurations: 150 lbs. and 300 lbs. flanges, FNPT, MNPT, butt weld, TTMA, and others upon request

Split Flange Swivel Joint Numbering System

SF	2	20	F	x	F	CS	1	1
Split Flange	Sizes Inches	Style	End Connection	x	End Connection	Nose Piece	Seal Material	Grease
SF	2 = 2"	20	F (FNPT)	x	F (FNPT)	CS carbon steel	0 = Baylast	0 = Standard
	3 = 3"	30	W (weld)	x	W (weld)	SS 316L stainless steel	1 = FKM	1 = Food grade
	4 = 4"	40	FG (150#)	x	FG (150#)	AL - Aluminum	2 = PTFE	2 = Silicone
		50	PF (300#)	x	PF (300#)		3 = EPDM	3 = Tribolube
		60	TF (TTMA)	x	TF (TTMA)		4 = FDA nitrile rubber	4 = Low temperature
		70	BP (BSPP)	x	BP (BSPP)		A = low temp FKM	
		80	BT (BSPT)	x	BT (BSPT)			
		10	M (MNPT)		M (MNPT)			

Split Flange Style 20 - Weld x Weld

Size	Part #	Material	Weight (lbs)	Dimension A
2"	SF220WXW	CS - carbon steel	13	3-7/8"
		SS - stainless steel	12	
		AL - aluminum	10	
3"	SF320WXW	CS - carbon steel	16	4-1/32"
		SS - stainless steel	16	
		AL - aluminum	13	
4"	SF420WXW	CS - carbon steel	21	3-25/32"
		SS - stainless steel	20	
		AL - aluminum	16	

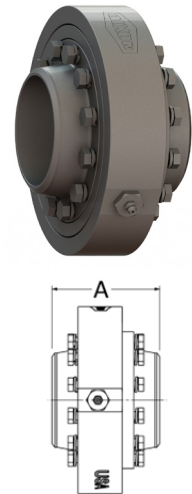

Split Flange Style - 20 FNPT x FNPT

Size	Part #	Material	Weight (lbs)	Dimension A
2"	SF220FXF	CS - carbon steel	16	7-1/4"
		SS - stainless steel	16	
		AL - aluminum	11	
3"	SF320FXF	CS - carbon steel	24	8-1/8"
		SS - stainless steel	23	
		AL - aluminum	15	
4"	SF420FXF	CS - carbon steel	34	8-1/2"
		SS - stainless steel	34	
		AL - aluminum	17	

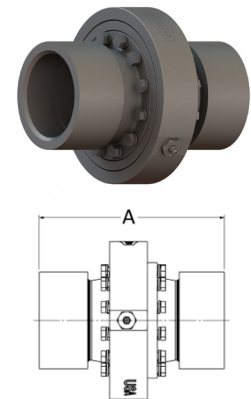

Split Flange Style 20 - 150# Flange x 150# Flange

Size	Part #	Material	Weight (lbs)	Dimension A
2"	SF220FGXFG	CS - carbon steel	24	8-25/32"
		SS - stainless steel	24	
		AL - aluminum	13	
3"	SF320FGXFG	CS - carbon steel	38	9-9/16"
		SS - stainless steel	37	
		AL - aluminum	20	
4"	SF420FGXFG	CS - carbon steel	51	9-25/32"
		SS - stainless steel	51	
		AL - aluminum	27	

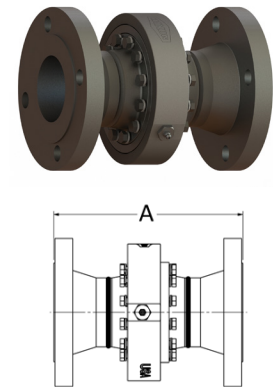

Split Flange Style 20 - 300# Flange x 300# Flange

Size	Part #	Material	Weight (lbs)	Dimension A
2"	SF220PFXPF	CS - carbon steel	27	9-3/8"
		SS - stainless steel	27	
		AL - aluminum	15	
3"	SF320PFXPF	CS - carbon steel	47	10-9/32"
		SS - stainless steel	47	
		AL - aluminum	23	
4"	SF420PFXPF	CS - carbon steel	70	10-19/32"
		SS - stainless steel	69	
		AL - aluminum	33	

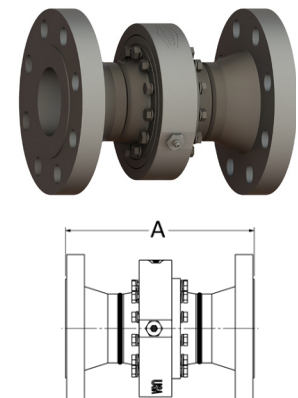

Split Flange Style 30 - FNPT x FNPT

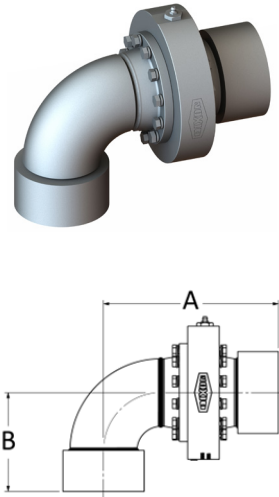

Size	Part #	Material	Weight (lbs)	Dimensions	
				A	B
2"	SF230FXF	CS - carbon steel	17	8-9/16"	4-11/16"
		SS - stainless steel	17		
		AL - aluminum	12		
3"	SF330FXF	CS - carbon steel	26	9-5/32"	5-1/8"
		SS - stainless steel	26		
		AL - aluminum	16		
4"	SF430FXF	CS - carbon steel	39	10-5/32"	6-3/8"
		SS - stainless steel	39		
		AL - aluminum	19		

Split Flange Style 30 - 150# Flange x 150# Flange

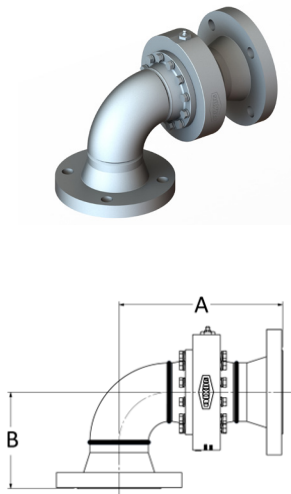

Size	Part #	Material	Weight (lbs)	Dimensions	
				A	B
2"	SF230FGXFG	CS - carbon steel	25	9-11/32"	5-15/32"
		SS - stainless steel	25		
		AL - aluminum	14		
3"	SF330FGXFG	CS - carbon steel	41	9-25/32"	5-25/32"
		SS - stainless steel	41		
		AL - aluminum	21		
4"	SF430FGXFG	CS - carbon steel	57	10-13/16"	7-1/32"
		SS - stainless steel	56		
		AL - aluminum	28		

Split Flange Style 30 - 300# Flange x 300# Flange

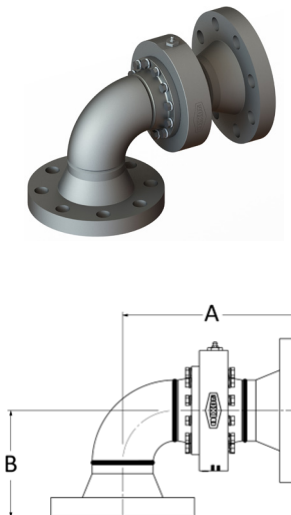

Size	Part #	Material	Weight (lbs)	Dimensions	
				A	B
2"	SF230PFXPF	CS - carbon steel	29	9-21/32"	5-25/32"
		SS - stainless steel	28		
		AL - aluminum	16		
3"	SF330PFXPF	CS - carbon steel	50	11-1/32"	7-1/32"
		SS - stainless steel	50		
		AL - aluminum	24		
4"	SF430PFXPF	CS - carbon steel	75	11-3/16"	7-13/32"
		SS - stainless steel	76		
		AL - aluminum	35		

Split Flange Style 40 - FNPT x FNPT

Size	Part #	Material	Weight (lbs)	Dimensions		
				A	B	C
2"	SF240FXF	CS - carbon steel	19	9-7/8"	4-13/16"	9-21/32"
		SS - stainless steel	18			
		AL - aluminum	12			
3"	SF340FXF	CS - carbon steel	29	10-1/32"	5-1/8"	10-1/4"
		SS - stainless steel	29			
		AL - aluminum	17			
4"	SF440FXF	CS - carbon steel	45	11-25/32"	6-3/8"	12-3/4"
		SS - stainless steel	44			
		AL - aluminum	21			

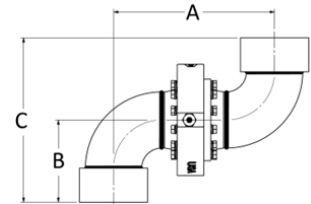

Split Flange Style 40 - 150# Flange x 150# Flange

Size	Part #	Material	Weight (lbs)	Dimensions		
				A	B	C
2"	SF240FGXFG	CS - carbon steel	26	9-7/8"	5-15/32"	10-29/32"
		SS - stainless steel	26			
		AL - aluminum	16			
3"	SF340FGXFG	CS - carbon steel	44	10-1/32"	5-3/4"	11-1/2"
		SS - stainless steel	43			
		AL - aluminum	22			
4"	SF440FGXFG	CS - carbon steel	62	11-25/32"	7"	14"
		SS - stainless steel	62			
		AL - aluminum	30			

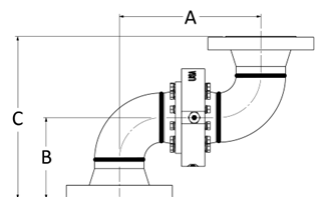

Split Flange Style 40 - 300# Flange x 300# Flange

Size	Part #	Material	Weight (lbs)	Dimensions		
				A	B	C
2"	SF240PFXPF	CS - carbon steel	30	9-7/8"	5-3/4"	11-1/2"
		SS - stainless steel	30			
		AL - aluminum	16			
3"	SF340PFXPF	CS - carbon steel	53	10-1/32"	6-1/8"	12-1/4"
		SS - stainless steel	53			
		AL - aluminum	25			
4"	SF440PFXPF	CS - carbon steel	81	11-25/32"	7-3/8"	14-3/4"
		SS - stainless steel	80			
		AL - aluminum	37			

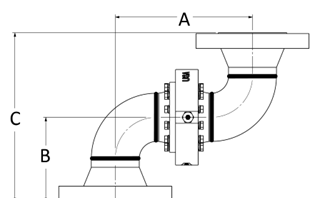

Split Flange Style 50 - FNPT x FNPT

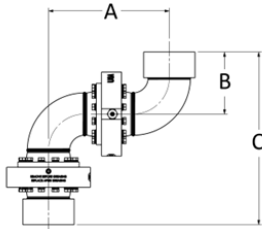

Size	Part #	Material	Weight (lbs)	Dimensions		
				A	B	C
2"	SF250FXF	CS - carbon steel	31	9-7/8"	4-11/16"	13-1/4"
		SS - stainless steel	31			
		AL - aluminum	22			
3"	SF350FXF	CS - carbon steel	46	10-1/32"	5-1/8"	14-9/32"
		SS - stainless steel	45			
		AL - aluminum	30			
4"	SF450FXF	CS - carbon steel	65	11-25/32"	6-3/8"	16-1/2"
		SS - stainless steel	65			
		AL - aluminum	37			

Split Flange Style 50 - 150# Flange x 150# Flange

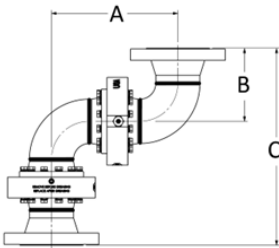

Size	Part #	Material	Weight (lbs)	Dimensions		
				A	B	C
2"	SF250FGXFG	CS - carbon steel	39	9-7/8"	5-1/2"	14-7/8"
		SS - stainless steel	38			
		AL - aluminum	24			
3"	SF350FGXFG	CS - carbon steel	60	10-1/32"	5-3/4"	15-17/32"
		SS - stainless steel	59			
		AL - aluminum	35			
4"	SF450FGXFG	CS - carbon steel	82	11-25/32"	7"	17-25/32"
		SS - stainless steel	82			
		AL - aluminum	46			

Split Flange Style 50 - 300# Flange x 300# Flange

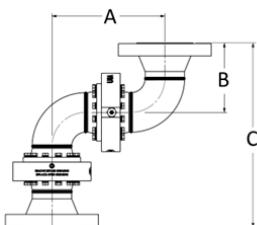

Size	Part #	Material	Weight (lbs)	Dimensions		
				A	B	C
2"	SF250PFXPF	CS - carbon steel	42	9-7/8"	5-3/4"	15-3/8"
		SS - stainless steel	42			
		AL - aluminum	26			
3"	SF350PFXPF	CS - carbon steel	69	10-1/32"	6-1/8"	16-9/32"
		SS - stainless steel	69			
		AL - aluminum	38			
4"	SF450PFXPF	CS - carbon steel	101	11-25/32"	7-3/8"	18-17/32"
		SS - stainless steel	100			
		AL - aluminum	52			

Split Flange Style 60 - FNPT x FNPT

Size	Part #	Material	Weight (lbs)	Dimension A
2"	SF260FXF	CS - carbon steel	30	8-5/8"
		SS - stainless steel	30	
		AL - aluminum	22	
3"	SF360FXF	CS - carbon steel	43	9-5/32"
		SS - stainless steel	43	
		AL - aluminum	29	
4"	SF460FXF	CS - carbon steel	60	10-1/8"
		SS - stainless steel	59	
		AL - aluminum	35	

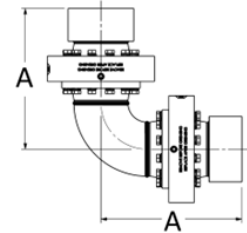

Split Flange Style 60 - 150# Flange x 150# Flange

Size	Part #	Material	Weight (lbs)	Dimension A
2"	SF260FGXFG	CS - carbon steel	37	9-3/8"
		SS - stainless steel	38	
		AL - aluminum	24	
3"	SF360FGXFG	CS - carbon steel	57	9-25/32"
		SS - stainless steel	57	
		AL - aluminum	34	
4"	SF460FGXFG	CS - carbon steel	77	10-3/4"
		SS - stainless steel	77	
		AL - aluminum	44	

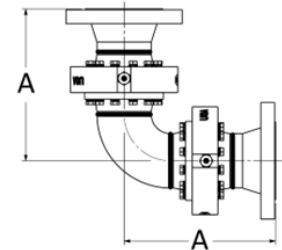

Split Flange Style 60 - 300# Flange x 300# Flange

Size	Part #	Material	Weight (lbs)	Dimension A
2"	SF260PFXPF	CS - carbon steel	41	9-5/8"
		SS - stainless steel	41	
		AL - aluminum	26	
3"	SF360PFXPF	CS - carbon steel	66	10-5/32"
		SS - stainless steel	66	
		AL - aluminum	37	
4"	SF460PFXPF	CS - carbon steel	96	11-1/8"
		SS - stainless steel	95	
		AL - aluminum	50	

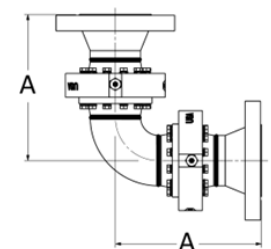

Split Flange Style 70 - FNPT x FNPT

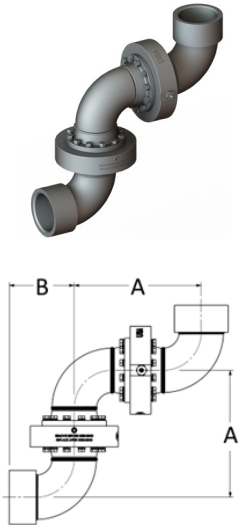

Size	Part #	Material	Weight (lbs)	Dimensions	
				A	B
2"	SF270FXF	CS - carbon steel	33	9-7/8"	4-11/16"
		SS - stainless steel	32		
		AL - aluminum	23		
3"	SF370FXF	CS - carbon steel	49	10-1/32"	5-1/8"
		SS - stainless steel	48		
		AL - aluminum	31		
4"	SF470FXF	CS - carbon steel	71	11-25/32"	6-3/8"
		SS - stainless steel	70		
		AL - aluminum	39		

Split Flange Style 70 - 150# Flange x 150# Flange

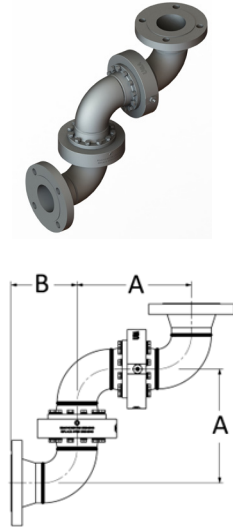

Size	Part #	Material	Weight (lbs)	Dimensions	
				A	B
2"	SF270FGXFG	CS - carbon steel	41	9-7/8"	5-1/2"
		SS - stainless steel	40		
		AL - aluminum	25		
3"	SF370FGXFG	CS - carbon steel	63	10-1/32"	5-25/32"
		SS - stainless steel	62		
		AL - aluminum	36		
4"	SF470FGXFG	CS - carbon steel	88	11-25/32"	7"
		SS - stainless steel	88		
		AL - aluminum	48		

Split Flange Style 70 - 300# Flange x 300# Flange

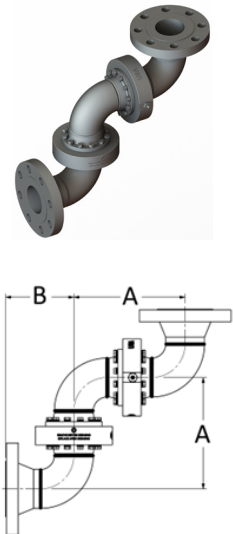

Size	Part #	Material	Weight (lbs)	Dimensions	
				A	B
2"	SF270PFXPF	CS - carbon steel	44	9-7/8"	5-1/2"
		SS - stainless steel	44		
		AL - aluminum	27		
3"	SF370PFXPF	CS - carbon steel	72	10-1/32"	5-25/32"
		SS - stainless steel	72		
		AL - aluminum	39		
4"	SF470PFXPF	CS - carbon steel	106	11-25/32"	7-3/8"
		SS - stainless steel	106		
		AL - aluminum	54		

Split Flange Swivel Components

Bearing Packs

Feature

- Single wide-set bearing race for high moment loads

Materials

- Through hardened forged carbon steel
- Carbon steel ball bearings
- FKM dust seals



Size	Part #
2"	2SFBP
3"	3SFBP
4"	4SFBP

Nose Pieces

Feature

- 2 required per bearing pack

Size	Aluminum Part #	Carbon Steel Part #	316 Stainless Steel Part #
2"	2SFNPAL	2SFNPCS	2SFNPSS
3"	3SFNPAL	3SFNPCS	3SFNPSS
4"	4SFNPAL	4SFNPCS	4SFNPSS



Seal Kits

Features

- Kits contain: seals, PTFE retainer, carbon steel bolts, and lock washers
- 1 required per bearing pack

Size	Baylast™ Part #	FKM Part #	PTFE Part #	EPDM Part #	Low Temperature FKM Part #	FDA Nitrile Rubber Part #
2"	2SFSK-BAYLAST	2SFSK-VI	2SFSK-TES	2SFSK-EP	2SFSK-VM125-75	2SFSK-FB
3"	3SFSK-BAYLAST	3SFSK-VI	3SFSK-TES	3SFSK-EP	3SFSK-VM125-75	3SFSK-FB
4"	4SFSK-BAYLAST	4SFSK-VI	4SFSK-TES	4SFSK-EP	4SFSK-VM125-75	4SFSK-FB



Split Flange Swivel Locking Kits

Applications

- Locks the swivel into a horizontal position
- Not to be used vertically

Feature

- Single or multiple hole design

Material

- Carbon steel

Size	Description	Part #
2"	locking multiple hole T-handle kit for split flange swivel joints	LA-2SFLOCKTHK-M
3"/4"	locking single hole T-handle kit for split flange swivel joints	LA-SFLOCKTHK-S
	locking multiple hole T-handle kit for split flange swivel joints	LA-SFLOCKTHK-M



Warning: This item is only intended to restrain the rotation during storage and is limited to a maximum of 12 in-lbs. of torque.

Split Flange Swivel Joint Seal Replacement Procedure

To change the seals in a Dixon® split flange swivel joint you will need the following items:

- 1/2" wrench or socket wrench with 1/2" sockets
- Torque wrench
- Application-appropriate grease
- Repair kit

1 Follow your company guidelines to properly shut down the system and confirm there is no residual pressure in the line. Support or remove any components necessary to disconnect at least one nose piece.

2 Remove all the bolts and washers from one of the nose pieces. Pick the side that gives the best access to the seal gland.

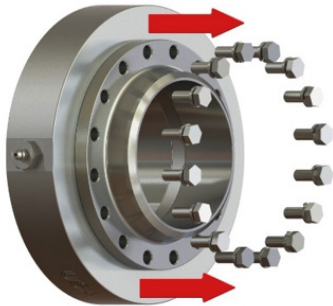

3a Remove and discard the old O-rings and PTFE H-ring. Clean the seal gland area.

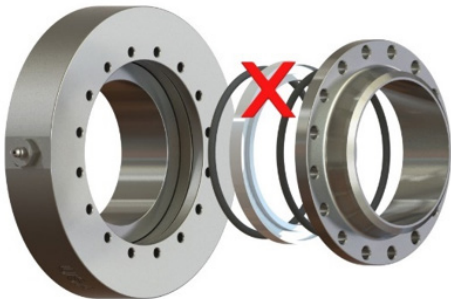

3b Lubricate the body and sleeve, new H-ring and O-rings with grease.

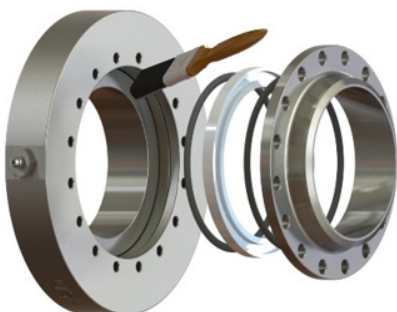

4 Install the replacement O-rings and the new H-ring. Make sure the O-rings are set in on each side of the H-ring. Be careful not to pinch the O-rings during reassembly.



5 Reinstall the nose piece using the new bolts and washers in the replacement kit. Do not reuse old bolts and washers.

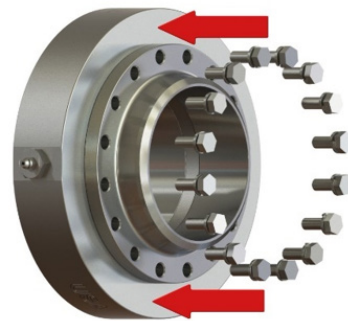

6 Torque the bolts to 25 ft-lbs. in a star pattern

Pressure testing is recommended prior to returning the swivel joint to service. If needed, this is a good time to clean and repaint any carbon steel parts to help protect them from the elements.

Once the seal replacement and pressure testing are complete the unit can be returned to service.

High Capacity Swivel Joints

New

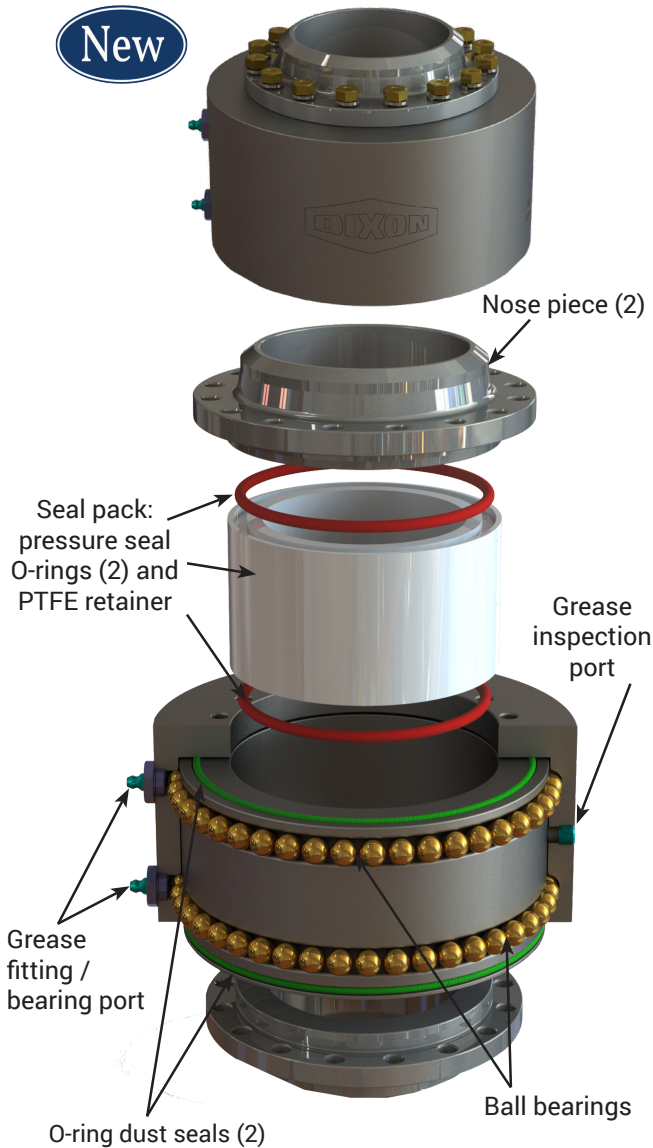

Applications

- For use in industries from petroleum, steel producing, blending plants, petrochemical, refining, mining, distilling, paint plants, farm irrigation and fertilizing, wastewater treatment, food and beverage process equipment, marine, and many more
- Ideal for high moment load applications on loading arms

Sizes

- 2", 3", and 4"

Features

- Bearing pack design allows easy seal change without removing the ball bearings
- Simple maintenance: remove one nose piece, replace seal pack, and reinstall with little downtime
- In-stream seal separates the wetted area from the ball bearings, allowing for longer bearing pack life compared to conventional swivels
- Dual wide-set bearing race and high strength bolts for higher moment loads
- Compact design for low-profile applications
- Full penetration weld

Materials

- Bearing pack: through hardened forged high-carbon alloy
- Material contact surfaces: stainless steel, carbon steel nose pieces
- Seals: Baylast™, FKM, PTFE, and more upon request

Specifications

- Pressure rating: up to **1,000 PSI**
- Standard temperature range with Baylast™ seals is **-30°F to 212°F (-34°C to 100°C)**; contact factory for other temperature requirements

Available options

- Swivel end configurations: 150 lbs. and 300 lbs. flanges, FNPT, MNPT, butt weld, TTMA, and others upon request

High Capacity Swivel Joints Numbering System

HC	2	20	F	x	F	CS	1	1
High Capacity	Sizes Inches	Style	End Connection	x	End Connection	Nose Piece	Seal Material	Grease
HC	2 = 2"	20	F (FNPT)	x	F (FNPT)	CS carbon steel	0 = Baylast	0 = Standard
	3 = 3"	30	W (weld)	x	W (weld)	SS 316L stainless steel	1 = FKM	1 = Food grade
	4 = 4"	40	FG (150#)	x	FG (150#)		2 = PTFE	2 = Silicone
		50	PF (300#)	x	PF (300#)		3 = EPDM	3 = Tribolube
		60	TF (TTMA)	x	TF (TTMA)		4 = FDA nitrile rubber	4 = Low temperature
		70	BP (BSPP)	x	BP (BSPP)		A = low temp FKM	
		80	BT (BSPT)	x	BT (BSPT)			
		10	M (MNPT)		M (MNPT)			

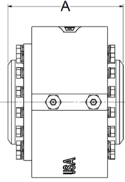

High Capacity Split Flange Style 20 - Weld x Weld

Size	Part #	Material
2"	HC220WXW	CS - carbon steel
		SS - stainless steel
3"	HC320WXW	CS - carbon steel
		SS - stainless steel
4"	HC420WXW	CS - carbon steel
		SS - stainless steel

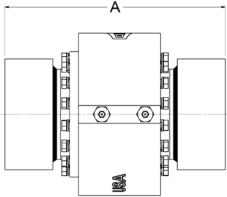

High Capacity Split Flange Style 20 - FNPT x FNPT

Size	Part #	Material
2"	HC220FXF	CS - carbon steel
		SS - stainless steel
3"	HC320FXF	CS - carbon steel
		SS - stainless steel
4"	HC420FXF	CS - carbon steel
		SS - stainless steel

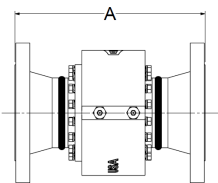
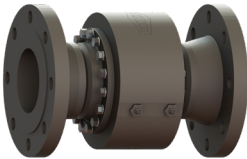

High Capacity Split Flange Style 20 - 150# Flange x 150# Flange

Size	Part #	Material
2"	HC220FGXFG	CS - carbon steel
		SS - stainless steel
3"	HC320FGXFG	CS - carbon steel
		SS - stainless steel
4"	HC420FGXFG	CS - carbon steel
		SS - stainless steel

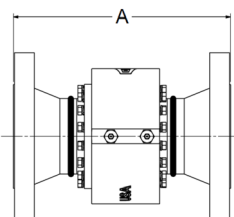
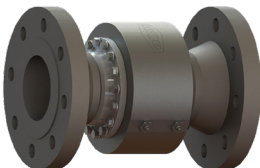

High Capacity Style 20 - 300# Flange x 300# Flange

Size	Part #	Material
2"	HC220PFXPF	CS - carbon steel
		SS - stainless steel
3"	HC320PFXPF	CS - carbon steel
		SS - stainless steel
4"	HC420PFXPF	CS - carbon steel
		SS - stainless steel

NOTE: Contact factory for weights and dimensions

High Capacity Split Flange Style 30 - FNPT x FNPT

Size	Part #	Material
2"	HC230FXF	CS - carbon steel
		SS - stainless steel
3"	HC330FXF	CS - carbon steel
		SS - stainless steel
4"	HC430FXF	CS - carbon steel
		SS - stainless steel

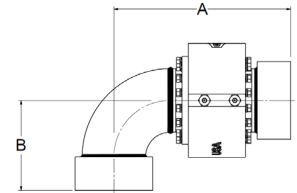

High Capacity Split Flange Style 30 - 150# Flange x 150# Flange

Size	Part #	Material
2"	HC230FGXFG	CS - carbon steel
		SS - stainless steel
3"	HC330FGXFG	CS - carbon steel
		SS - stainless steel
4"	HC430FGXFG	CS - carbon steel
		SS - stainless steel

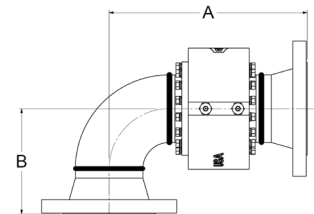

High Capacity Split Flange Style 30 - 300# Flange x 300# Flange

Size	Part #	Material
2"	HC230PFXPF	CS - carbon steel
		SS - stainless steel
3"	HC330PFXPF	CS - carbon steel
		SS - stainless steel
4"	HC430PFXPF	CS - carbon steel
		SS - stainless steel

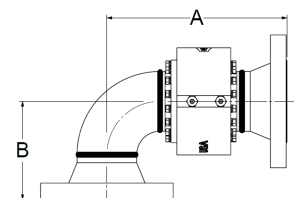
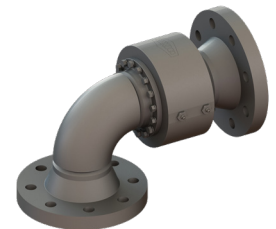

NOTE: Contact factory for weights and dimensions

High Capacity Split Flange Style 40 - FNPT x FNPT

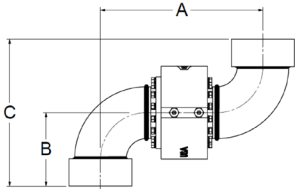

Size	Part #	Material
2"	HC240FXF	CS - carbon steel
		SS - stainless steel
3"	HC340FXF	CS - carbon steel
		SS - stainless steel
4"	HC440FXF	CS - carbon steel
		SS - stainless steel

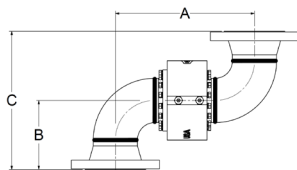

High Capacity Split Flange Style 40 - 150# Flange x 150# Flange

Size	Part #	Material
2"	HC240FGXFG	CS - carbon steel
		SS - stainless steel
3"	HC340FGXFG	CS - carbon steel
		SS - stainless steel
4"	HC440FGXFG	CS - carbon steel
		SS - stainless steel

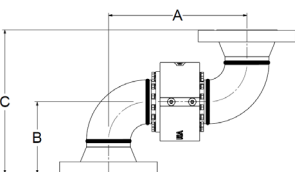

High Capacity Split Flange Style 40 - 300# Flange x 300# Flange

Size	Part #	Material
2"	HC240PFXPF	CS - carbon steel
		SS - stainless steel
3"	HC340PFXPF	CS - carbon steel
		SS - stainless steel
4"	HC440PFXPF	CS - carbon steel
		SS - stainless steel

NOTE: Contact factory for weights and dimensions

High Capacity Split Flange Style 50 - FNPT x FNPT

Size	Part #	Material
2"	HC250FXF	CS - carbon steel
		SS - stainless steel
3"	HC350FXF	CS - carbon steel
		SS - stainless steel
4"	HC450FXF	CS - carbon steel
		SS - stainless steel

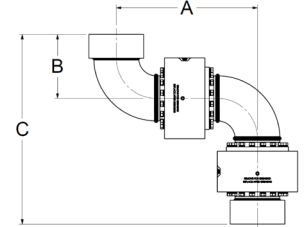

High Capacity Split Flange Style 50 - 150# Flange x 150# Flange

Size	Part #	Material
2"	HC250FGXFG	CS - carbon steel
		SS - stainless steel
3"	HC350FGXFG	CS - carbon steel
		SS - stainless steel
4"	HC450FGXFG	CS - carbon steel
		SS - stainless steel

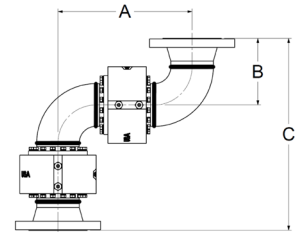

High Capacity Split Flange Style 50 - 300# Flange x 300# Flange

Size	Part #	Material
2"	HC250PFXPF	CS - carbon steel
		SS - stainless steel
3"	HC350PFXPF	CS - carbon steel
		SS - stainless steel
4"	HC450PFXPF	CS - carbon steel
		SS - stainless steel

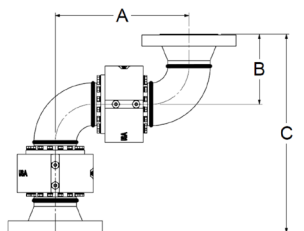

NOTE: Contact factory for weights and dimensions

High Capacity Split Flange Style 60 - FNPT x FNPT

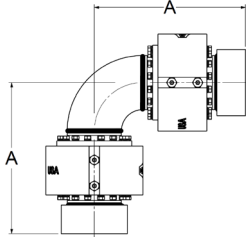

Size	Part #	Material
2"	HC260FXF	CS - carbon steel
		SS - stainless steel
3"	HC360FXF	CS - carbon steel
		SS - stainless steel
4"	HC460FXF	CS - carbon steel
		SS - stainless steel

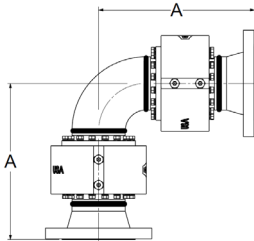

High Capacity Split Flange Style 60 - 150# Flange x 150# Flange

Size	Part #	Material
2"	HC260FGXFG	CS - carbon steel
		SS - stainless steel
3"	HC360FGXFG	CS - carbon steel
		SS - stainless steel
4"	HC460FGXFG	CS - carbon steel
		SS - stainless steel

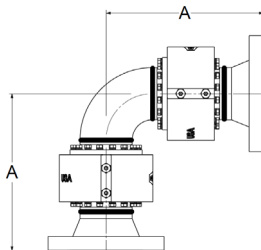

High Capacity Split Flange Style 60 - 300# Flange x 300# Flange

Size	Part #	Material
2"	HC260PFXPF	CS - carbon steel
		SS - stainless steel
3"	HC360PFXPF	CS - carbon steel
		SS - stainless steel
4"	HC460PFXPF	CS - carbon steel
		SS - stainless steel

NOTE: Contact factory for weights and dimensions

High Capacity Split Flange Style 70 - FNPT x FNPT

Size	Part #	Material
2"	HC270FXF	CS - carbon steel
		SS - stainless steel
3"	HC370FXF	CS - carbon steel
		SS - stainless steel
4"	HC470FXF	CS - carbon steel
		SS - stainless steel

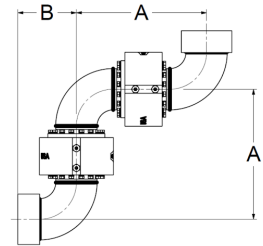

High Capacity Split Flange Style 70 - 150# Flange x 150# Flange

Size	Part #	Material
2"	HC270FGXFG	CS - carbon steel
		SS - stainless steel
3"	HC370FGXFG	CS - carbon steel
		SS - stainless steel
4"	HC470FGXFG	CS - carbon steel
		SS - stainless steel

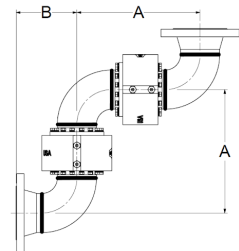

High Capacity Split Flange Style 70 - 300# Flange x 300# Flange

Size	Part #	Material
2"	HC270PFXPF	CS - carbon steel
		SS - stainless steel
3"	HC370PFXPF	CS - carbon steel
		SS - stainless steel
4"	HC470PFXPF	CS - carbon steel
		SS - stainless steel

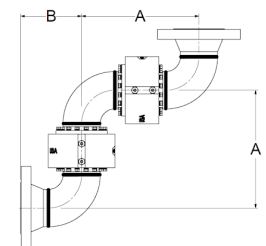

NOTE: Contact factory for weights and dimensions

High Capacity Split Flange Swivel Components

Bearing Packs



Feature

- Dual wide-set bearing race for higher moment loads

Materials

- Through hardened forged carbon steel
- Carbon steel ball bearings
- FKM dust seals

Size	Part #
2"	2HCBP
3"	3HCBP
4"	4HCBP

Nose Pieces

Features

- 2 required per bearing pack
- Sch 80 butt weld ends



Material

- Carbon steel and 316 stainless steel

Size	Carbon Steel Part #	316 Stainless Steel Part #
2"	2HCNPCS	2HCNPSS
3"	3HCNPCS	3HCNPSS
4"	4HCNPCS	4HCNPSS

Seal Kits

Features

- Kits contain: seals, PTFE retainer, carbon steel bolts, and lock washers
- 1 required per bearing pack



Size	Baylast™ Part #	FKM Part #	PTFE Part #	EPDM Part #	FDA Nitrile Rubber Part #
2"	2HCSK-BAYLAST	2HCSK-VI	2HCSK-TESS	2HCSK-EP	2HCSK-FB
3"	3HCSK-BAYLAST	3HCSK-VI	3HCSK-TESS	3HCSK-EP	3HCSK-FB
4"	4HCSK-BAYLAST	4HCSK-VI	4HCSK-TESS	4HCSK-EP	4HCSK-FB

High-Capacity Swivel Joint Seal Replacement Procedure

To change the seals in a Dixon® split flange swivel joint you will need the following items:

- 1/2" wrench or socket wrench with 1/2" socket
- Torque wrench
- Application-appropriate grease
- Repair kit

1 Follow your company guidelines to properly shut down the system and confirm there is no residual pressure in the line. Support or remove any components necessary to disconnect at least one nose piece.

2 Remove all the bolts and washers from one of the nose pieces. Pick the side that gives the best access to the seal gland.



3 Remove and discard the old O-rings and PTFE H-ring. Clean the seal gland area.

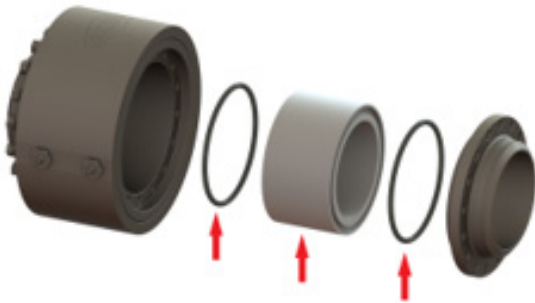

4 Lubricate the seal gland areas located on bottom of nose pieces touching the O-rings, the new H-ring seal grooves, and O-rings with grease.



5 Install the replacement O-rings and the new H-ring. Make sure the O-rings are set in each groove on the top and bottom of the H-ring. Be careful not to pinch the O-rings during reassembly.

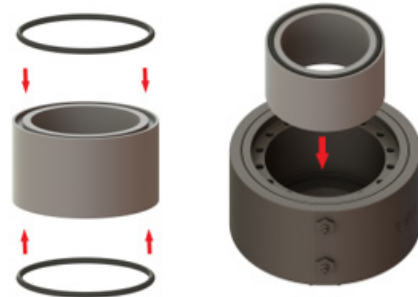

6 Reinstall the nose piece using the new bolts and washers in the replacement kit. Do not reuse old bolts and washers.

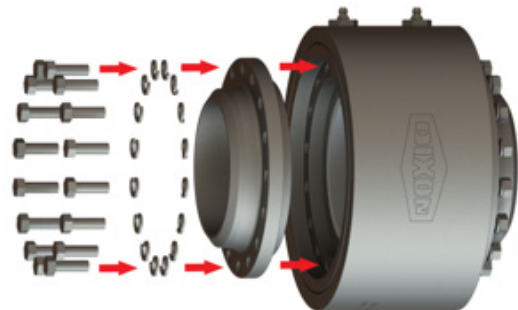

7 Torque the bolts to 25 ft-lbs. in a star pattern



Pressure testing is recommended prior to returning the swivel joint to service. If needed, this is a good time to clean and repaint any carbon steel parts to help protect them from corrosion.

Once the seal replacement and pressure testing are complete the unit can be returned to service.

Dixon® Loading Arms

A loading arm is a dynamic system allowing for the transfer of media such as liquids, liquified gas, or dry bulk from one storage vessel to another. Consisting of a combination of swivel joints, pipe and/or hose legs, a counterbalance, and various end connections, loading arms can be configured for both top loading and bottom loading applications. Dixon loading arms are ideal for a wide range of applications, transferring product to and from tank trucks or rail cars as well as to drums and totes.

Sizes

- 2", 3", 4", 6", and more upon request

Features

- Engineered with serviceability in mind
- Counterbalance options include compression springs, torsion springs, and counterweights
- Standard and customized options available
- Torsion spring counterbalance offered in left and right hand
- Multiple spring rates available for different load requirements
- Counterweight option available with 2 or 4 sliding weights
- Wide variety of end connections and accessories available

Materials

- Pipe leg materials offered: aluminum, carbon steel, and 316 stainless steel
- Available seals include: nitrile rubber, FKM, low-temperature FKM, PTFE, EPDM, and food-grade nitrile
- Drop hoses available in composite or stainless steel

NOTE: Visit dixonvalve.com/en/dixon-loading-arms for additional product information or call 888.226.4673.

Dixon Loading Arm Configurations

Counterweight Loading Arms

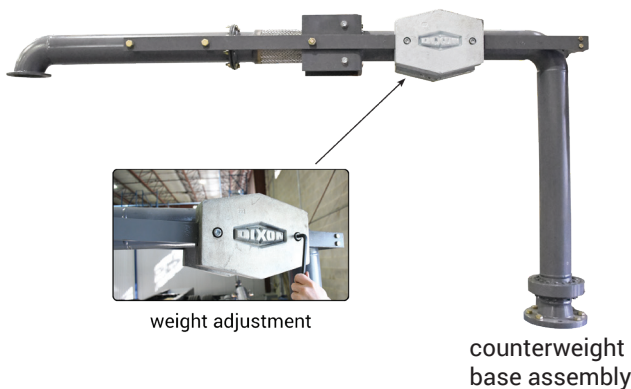

A-Frame Loading Arm with Rigid Drop Pipe



A-Frame Loading Arm with Drop Hose



Horizontal Hose Loader



Dixon® Loading Arm Configurations

Fixed Reach Loading Arm



Telescoping Loading Arm

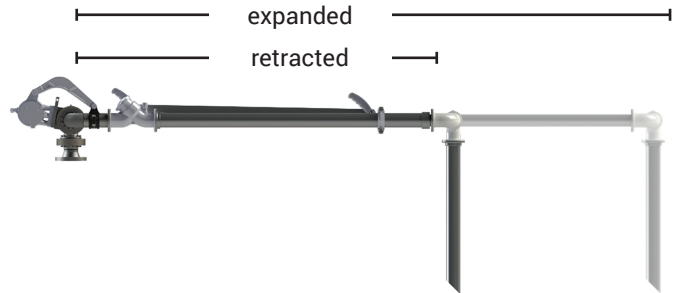

Scissor Style Loading Arm

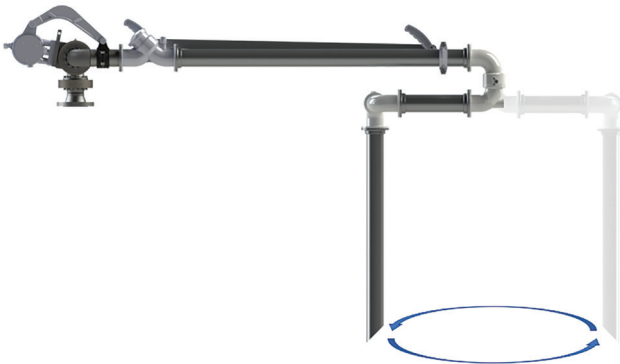

Unsupported Boom Loading Arm



Supported Boom Loading Arm



**Additional
Sizes and Configurations
Coming
Soon!**

NOTE: Visit dixonvalve.com/en/dixon-loading-arms for additional product information or call 877.963.4966.

Base Swivels with Counterbalance

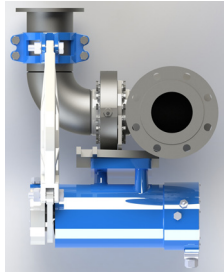

left hand style

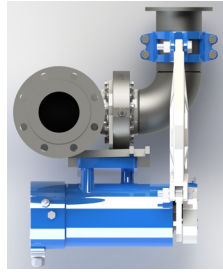

right hand style

Sizes

- Carbon steel V-ring: 3", 4", and 6"
- Carbon steel split flange: 2", 3", and 4"
- 316 stainless steel split flange: 2", 3", and 4"

Features

- Torsion spring counterbalance offered in right or left hand
- Style 50 or 70 available for base swivels based on configuration and flow of media
- Connecting arm and clamp included

Materials

- Base swivel materials offered: carbon steel and 316 stainless steel
- Available seals include: nitrile rubber, FKM, low temperature FKM, PTFE, EPDM, or food-grade nitrile rubber

Specifications

- Standard configurations below include carbon steel split flange base swivel, ESB1 torsion spring counterbalance, 150# flange inlet, and TTMA flange outlet
- Connection options include: 150# flange, 300# flange, and TTMA flange
- Other options available upon request
- Three spring rates available: Light, medium, and heavy. Contact Dixon® to determine which is best for your application.

Orientation	Seals	Counterbalance Spring	3" Part #	4" Part #
UFRH	Nitrile rubber	Light	AB3G00000000000	AB4G00000000000
		Medium	BB3G00000000000	BB4G00000000000
		Heavy	CB3G00000000000	CB4G00000000000
	FKM	Light	AV3G00000000000	AV4G00000000000
		Medium	BV3G00000000000	BV4G00000000000
		Heavy	CV3G00000000000	CV4G00000000000
UFLH	Nitrile rubber	Light	EB3G00000000000	EB4G00000000000
		Medium	FB3G00000000000	FB4G00000000000
		Heavy	GB3G00000000000	GB4G00000000000
	FKM	Light	EV3G00000000000	EV4G00000000000
		Medium	FV3G00000000000	FV4G00000000000
		Heavy	GV3G00000000000	GV4G00000000000



upfeed right-hand (UFRH)

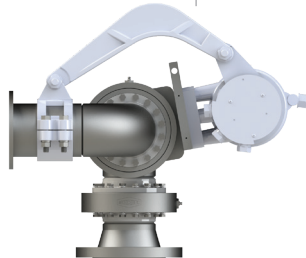

upfeed left-hand (UFLH)

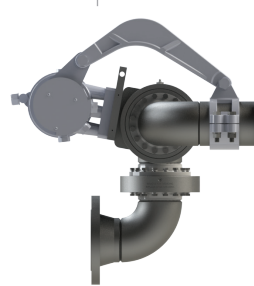

horizontal upfeed right-hand (HUF RH)*

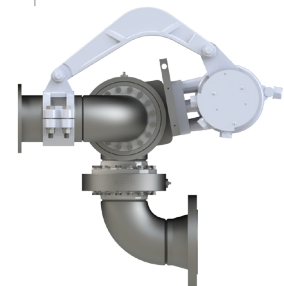

horizontal upfeed left-hand (HUF LH)*

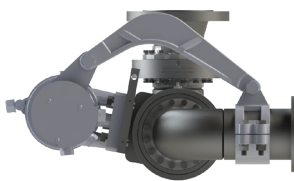

downfeed right-hand (DFRH)*

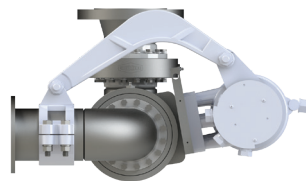

downfeed left-hand (DFLH)*



horizontal downfeed right-hand (HDFRH)*

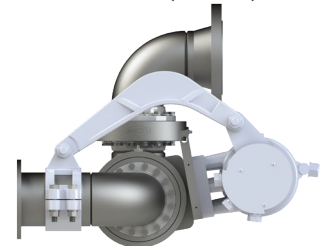

horizontal downfeed left-hand (HDFLH)*

*Not listed in chart above, contact Dixon® for details

Loading Arm Swivels

Features

- TTMA-flanged aluminum loading arm swivel
- Optional D-handle or ball handle is used to guide the connection of the API load coupler to the adapter on the tank truck
- Optional long radius elbow improves the flow into the API load coupler and provides spacing between the load arm and the tank truck
- Can be used with flange extensions and other TTMA flanged accessories
- Available seals include: nitrile rubber, FKM, low temperature FKM, EPDM, or food-grade nitrile

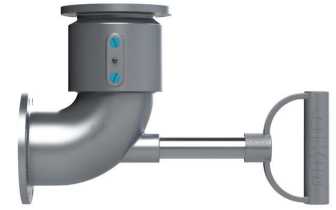

style 30, short radius



style 30, long radius

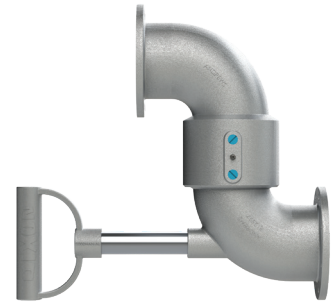

style 40

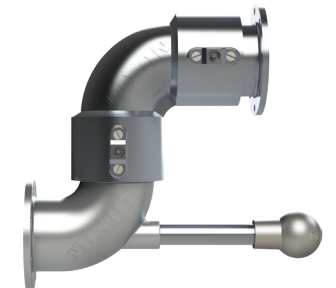

style 50

Description	Handle	Seal	3" Part #	4" Part #
style 20	no handle	Nitrile rubber	320TFXTFAL00000	420TFXTFAL00000
		FKM	320TFXTFAL11000	420TFXTFAL11000
style 30 short radius	D-handle	Nitrile rubber	33HTFXTFAL00000	43HTFXTFAL00000
		FKM	33HTFXTFAL11000	43HTFXTFAL11000
	ball handle	Nitrile rubber	33BTFXTFAL00000	43BTFXTFAL00000
		FKM	33BTFXTFAL11000	43BTFXTFAL11000
	no handle	Nitrile rubber	330TFXTFAL00000	430TFXTFAL00000
		FKM	330TFXTFAL11000	430TFXTFAL11000
style 30 long radius	D-handle	Nitrile rubber	---	43HTFTFLAL00000
		FKM	---	43HTFTFLAL11000
	ball handle	Nitrile rubber	---	43BTFTFLAL00000
		FKM	---	43BTFTFLAL11000
	no handle	Nitrile rubber	---	430TFTFLAL00000
		FKM	---	430TFTFLAL11000
style 40	D-handle	Nitrile rubber	34HTFXTFAL00000	44HTFXTFAL00000
		FKM	34HTFXTFAL11000	44HTFXTFAL11000
	ball handle	Nitrile rubber	34BTFXTFAL00000	44BTFXTFAL00000
		FKM	34BTFXTFAL11000	44BTFXTFAL11000
	no handle	Nitrile rubber	340TFXTFAL00000	440TFXTFAL00000
		FKM	340TFXTFAL11000	440TFXTFAL11000
style 50	D-handle	Nitrile rubber	35HTFXTFAL00000	45HTFXTFAL00000
		FKM	35HTFXTFAL11000	45HTFXTFAL11000
	ball handle	Nitrile rubber	35BTFXTFAL00000	45BTFXTFAL00000
		FKM	35BTFXTFAL11000	45BTFXTFAL11000
	no handle	Nitrile rubber	350TFXTFAL00000	450TFXTFAL00000
		FKM	350TFXTFAL11000	450TFXTFAL11000

Loading Arm Swivel Replacement Parts

Description	Part #
1" schedule 80 aluminum nipple	ATN100X7
ball-style handle	100BHAN-AL
D-Style heavy-duty shovel handle	100DHAN-AL



100*BHAN-AL



ATN100X7

TTMA Weldable Flanges

Application

- Used in applications where a device such as a valve or sight flow with a TTMA flange needs to be connected to a pipe; the TTMA weldable flange is welded to the pipe and the desired device is bolted on.

Features

- Flanges are 3/8" thick
- Easily connect with any item that has a 3" or 4" TTMA flange

Material

- Aluminum

Specification

- Flange connections are manufactured to connect with the Tank Truck Manufacturers Association (TTMA) flange pattern, see page 68 for flange dimensions.



TTF3AL



TTF400SP

Part #	Description
TTF3AL	3" TTMA butt weld on flange
TTF4AL	4" TTMA butt weld on flange
TTF300SP	3" TTMA socket weld on flange
TTF400SP	4" TTMA socket weld on flange
TTMA-32C	2" CS TTMA slip-on plate flange
TTMA-48C	3" CS TTMA slip-on plate flange
TTMA-64C	4" CS TTMA slip-on plate flange

Product instruction sheets and technical data, can be viewed at dixonvalve.com

TTMA PTFE Envelope Klinger® Gasket Kit

Features

- TTMA PTFE envelope Klinger® gasket with 3/8" bolts and self-locking nuts

Sizes

- 3"-4"



400GTTFTK-1758Z



400GTTFTK-3008Z

Size	Bolt Length	Part #
3"	1-1/2"	300GTTFTK-1508Z
	1-3/4"	300GTTFTK-1758Z
	2"	300GTTFTK-2008Z
	3"	300GTTFTK-3008Z
	3-1/2"	300GTTFTK-3508Z
4"	1-1/2"	400GTTFTK-1508Z
	1-3/4"	400GTTFTK-1758Z
	2"	400GTTFTK-2008Z
	3"	400GTTFTK-3008Z
	3-1/2"	400GTTFTK-3508Z

TTMA Baylast™ Gasket Kit

Features

- TTMA Baylast gasket with 3/8" bolts and self-locking nuts

Sizes

- 3"-4"



400GTTFBL-1758Z



400GTTFBL-3008Z

Size	Bolt Length	Part #
3"	1-1/2"	300GTTFBL-1508Z
	1-3/4"	300GTTFBL-1758Z
	2"	300GTTFBL-2008Z
	3"	300GTTFBL-3008Z
	3-1/2"	300GTTFBL-3508Z
4"	1-1/2"	400GTTFBL-1508Z
	1-3/4"	400GTTFBL-1758Z
	2"	400GTTFBL-2008Z
	3"	400GTTFBL-3008Z
	3-1/2"	400GTTFBL-3508Z

TTMA Flange Gaskets

Size	O.D.	I.D.	Thk.	Material	Part #
2"	4-1/2"	2-5/8"	1/8"	Baylast™	200GTTFBL
	5-5/8"	3-1/2"	1/8"	Cork / nitrile rubber	300GTTFCB
	5-5/16"	3-1/4"	5/32"	PTFE envelope with Klinger filler	300GTTFTK
3"	5-5/8"	3-1/2"	1/8"	Klingersil® C-4300	300GTTFK
	5-29/32"	3-1/2"	3/32"	PTFE with fiber core	40321TF
	7-1/4"	5"	5/32"	PTFE with soft fiber core	40364TF
	7-1/4"	5"	1/8"	Baylast	40364BL
	5-5/8"	3-5/8"	1/8"	Baylast	300GTTFBL
	6-5/8"	4-9/16"	1/8"	Cork / nitrile rubber	400GTTFCB
4"	6-7/8"	4-5/16"	5/32"	PTFE envelope with Klinger filler	400GTTFTK
	6-5/8"	4-9/16"	1/8"	Klingersil C-4401	400GTTFK
	6-7/8"	4-9/16"	3/32"	PTFE with fiber core	40322TF
	8-3/8"	5-7/8"	5/32"	PTFE with soft fiber core	40323TF
	8-1/4"	5-7/8"	1/8"	Baylast	40323BL
	6-5/8"	4-5/8"	1/8"	Baylast	400GTTFBL



NOTE: For flange dimensions, diagrams, and additional information, please reference dixonvalve.com.

150 lb. Flange Gaskets

Features

- Standard drop-ring type all 1/16" thick
- For flange dimensional information and diagrams please reference dixonvalve.com

Size	Neoprene Part #	PTFE Part #
1"	NG10	---
1-1/4"	NG15	---
1-1/2"	NG20	---
2"	NG25	PG25
2-1/2"	NG30	---
3"	NG35	PG35
4"	NG40	PG40
5"	NG50	---
6"	NG60	PG60
8"	NG80	---



neoprene



PTFE

150 lb. PTFE Flange Gasket Kit

Features

- 150 lb. PTFE flange gasket with 5/8" bolts, nuts, and lock washers

Sizes

- 3"-4"

Size	Bolt Length	Part #
3"	3"	PG35-3008Z
	3-1/2"	PG35-3508Z
4"	3"	PG40-3008Z
	3-1/2"	PG40-3508Z



PG35-3008Z

150 lb. Neoprene Flange Gasket Kit

Features

- 150 lb. neoprene flange gasket with 5/8" bolts, nuts, and lock washers

Sizes

- 3"-4"

Size	Bolt Length	Part #
3"	3"	NG35-3008Z
	3-1/2"	NG35-3508Z
4"	3"	NG40-3008Z
	3-1/2"	NG40-3508Z



NG40-3008Z

150 lb. ANSI Forged Flanges

Sizes

- 1" - 12"

Features

- Raised face: Slip-On and Weld Neck

Materials

- Carbon steel
- 316 stainless steel

150 lb. Slip-On Flange



150 lb. Slip-On Flange

Size	Number of Bolts	Carbon Steel Part #	316 Stainless steel Part #
1"	4	SO100	SOR100
1-1/4"	4	SO125	--
1-1/2"	4	SO150	SOR150
2"	4	SO200	SOR200
2-1/2"	4	SO250	--
3"	4	SO300	SOR300
4"	8	SO400	SOR400
5"	8	SO500	--
6"	8	SO600	SOR600
8"	8	SO800	SOR800
10"	12	SO1000	SOR1000
12"	12	SO1200	SOR1200

150 lb. Weld Neck Flange



150 lb. Weld Neck Flange

Size	Number of Bolts	Carbon Steel Part #	316 Stainless steel Part #
1"	4	WN100	WNR10015
1-1/4"	4	WN125	WNR12515
1-1/2"	4	WN150	WNR15015
2"	4	WN200	WNR20015
2-1/2"	4	WN250	WNR25015
3"	4	WN300	WNR30015
4"	8	WN400	WNR40015
5"	8	WN500	WNR50015
6"	8	WN600	WNR60015
8"	8	WN800	WNR80015
10"	12	WN1000	WNR100015
12"	12	WN1200	WNR120015

NPT Threaded One End Pipe Fittings

Size	Overall Length	Carbon Steel Part #	316 Stainless Steel Part #	Aluminum Part #
1"	2"	PN1000	---	---
1-1/4"	2"	PN1250	---	---
1-1/2"	2"	PN1500	PNR1500	---
2"	2"	PN2000	PNR2000	APN2000
2-1/2"	3"	PN2500	---	---
3"	3"	PN3000	PNR3000	APN3000
4"	4"	PN4000	PNR4000	APN4000



PN3000

NPT Threaded Female Half Couplings

Size	Carbon Steel Part #	316 Stainless Steel Part #	Aluminum Part #
1"	1HCPLGCS	1HCPLGSS	1HCPLGAL
1-1/4"	125HCPLGCS	125HCPLGSS	125HCPLGAL
1-1/2"	150HCPLGCS	150HCPLGSS	150HCPLGAL
2"	2HCPLGCS	2HCPLGSS	2HCPLGAL
2-1/2"	250HCPLGCS	250HCPLGSS	250HCPLGAL
3"	3HCPLGCS	3HCPLGSS	3HCPLGAL
4"	4HCPLGCS	4HCPLGSS	4HCPLGAL



150HCPLGSS

Grease Fittings

Carbon Steel without Ball Check Part #	Carbon Steel with Ball Check Part #	316 Stainless Steel with Ball Check Part #
GP	GPBCCS	GPBCSS



GP

Set Screws

Size	Carbon Steel Part #	316 Stainless Steel Part #
3/8"	38SET	38SETSS
7/16"	716SET	716SETSS
5/8"	58SET	58SETSS
7/8"	78SET	78SETSS
9/8"	98SET	98SETSS



78SET



38SET

TTMA Handle Kits



TTMAHK-C



TTMAHK-LB

Application

- For various applications that utilize 4" TTMA connections, allowing for improved ergonomics when handling hoses

Features

- Mounting plate mates up to TTMA flange
- Lightweight construction

Size	Description	Aluminum Part #
4"	Compact with D-handle	TTMAHK-C
4"	Long with ball handle	TTMAHK-LB

NOTE: Nuts and bolts not included

Thread Sealant Paste

Application

- Not for use in oxygen applications



Specification

- Temperature range: -50°F to 400°F (-45°C to 204°C)



Size	Part #	Optional Qty
1/4 pint	LCTS14	24
1/2 pint	LCTS1	24
1 pint	LCTS2	12
1 quart	LCTS3	12

Joint Sealant Gasket Material

Features

- GORE-TEX interchangeable
- Form-in-place expanded PTFE gasket material with adhesive backing
- Manufactured from 100% virgin PTFE
- Unaffected by all common chemicals (pH from 0-14)
- Unlimited shelf life
- Resilient with low cold flow
- Requires less force than standard gasket materials
- Made in the USA
- Larger spools are available; consult Dixon® for price and availability

Specifications

- Pressure range: **vacuum to 3000 PSI**
- Temperature range: **-450°F to 600°F (-268°C to 316°C)**

Approval

- FDA compliant #21CFR177.1550



Size	Length	Part #
1/4"	20'	LCJS4-20
1/4"	50'	LCJS4-50
3/8"	25'	LCJS6-25
1/2"	15'	LCJS8-15
3/4"	15'	LCJS12-15

American Made PTFE Tape (Purple)

Features

- Superior quality
- Not for use in oxygen applications

Specifications

- Temperature range: -450°F to 500°F (-268°C to 260°C)
- Thickness: 3.5 mil (0.0035 mm)

Size	Length	Part #
1/2"	520"	TTPM50-520
	700"	TTPM50-700
	1429"	TTPM50-1429
3/4"	520"	TTPM75-520
	700"	TTPM75-700
	1429"	TTPM75-1429
1"	520"	TTPM100-520
	700"	TTPM100-700
	1429"	TTPM100-1429



Industrial PTFE Tape (White)

Feature

- Not for use in oxygen applications

Specifications

- Thickness: 3.5 mil (0.0035 mm)
- Temperature range: -212°F to 500°F (-136°C to 260°C)

Size	Length	Part #	Optional Qty
1/2"	260"	TTA50	550
	520"	TTB50	500
	1296"	TTC50	250
3/4"	260"	TTA75	350
	520"	TTB75	350
1"	520"	TTB100	250

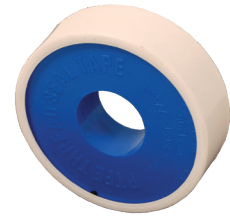

Stainless Steel PTFE Tape (Gray)

Application

- Useful on stainless steel threaded joints or connections

Features

- Not for use in oxygen applications
- PTFE with nickel added, nickel acts like a ball bearing
- Made in the U.S.

Specifications

- Thickness: 4 mil
- Temperature range: -450°F to 550°F (-268°C to 288°C)

Size	Length	Part #	Optional Qty
1/2"	260"	TTA50SS	10



Industrial Heavy Duty PTFE Tape (Pink)

Feature

- Not for use in oxygen applications

Specifications

- Thickness: 4 mil
- Temperature range: -400°F to 500°F (-240°C to 260°C)

Size	Length	Part #	Optional Qty
1/2"	540"	TTBP50	500



PTFE Tape for LP Gas (Yellow)

Feature

- Not for use in oxygen applications

Approval

- Underwriters Listed

Specifications

- Thickness: 4 mil
- Maximum temperature: 500°F (260°C)

Size	Length	Part #	Optional Qty
1/2"	260"	TTA50LP	500



Flange Bolt Tightening Sequence (Use appropriate gaskets and bolts)

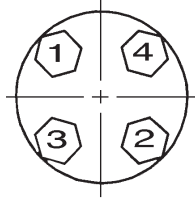

4 Bolt

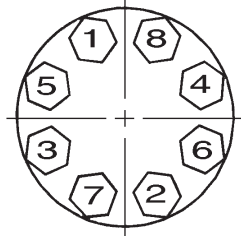

8 Bolt

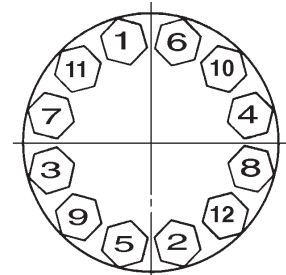

12 Bolt

Flange Diagrams

Threaded Applications

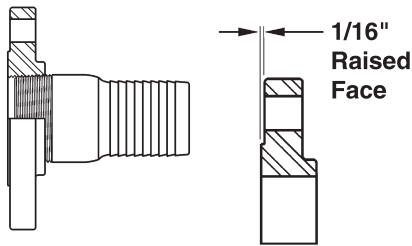

Threaded flange with raised face

Welded Applications

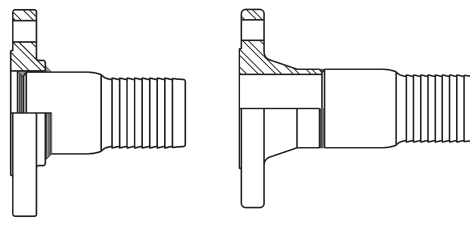

Slip-on flange with raised face

Weld neck flange with raised face

Floating Applications (flange free to swivel)

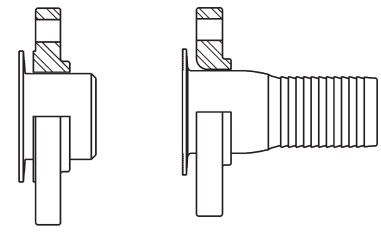

Slip-on flange with raised face

Lap-joint flange

Dimensions of 150 Lb. ASA Steel Flanges

Nominal Pipe Size	Flange O.D.	Thickness ¹	O.D. of Raised Face	Diameter of Bolt Circle	Number of Bolts	Diameter of Bolt Holes	Diameter of Bolts
1"	4-1/4"	9/16"	2"	3-1/8"	4	5/8"	1/2"
1-1/4"	4.62"	5/8"	2-1/2"	3-1/2"	4	5/8"	1/2"
1-1/2"	5"	11/16"	2-7/8"	3-7/8"	4	5/8"	1/2"
2"	6"	3/4"	3-5/8"	4-3/4"	4	3/4"	5/8"
2-1/2"	7"	7/8"	4-1/8"	5-1/2"	4	3/4"	5/8"
3"	7-1/2"	15/16"	5"	6"	4	3/4"	5/8"
4"	9"	15/16"	6-3/16"	7-1/2"	8	3/4"	5/8"
5"	10"	15/16"	7-5/16"	8-1/2"	8	7/8"	3/4"
6"	11"	1"	8-1/2"	9-1/2"	8	7/8"	3/4"
8"	13-1/2"	1-1/8"	10-5/8"	11-3/4"	8	7/8"	3/4"
10"	16"	1-3/16"	12-3/4"	14-1/4"	12	1"	7/8"
12"	19"	1 1/4"	15"	17"	12	1"	7/8"

¹ 1/16" raised face is included in the thickness

Dimensions of Tank Truck Flanges (TTMA Drilling)

Nominal Pipe Size	Flange O.D.	Thickness ¹	Diameter of Bolt Circle	Number of Bolts	Diameter of Bolt Holes	Diameter of Bolts
3"	5-5/8"	3/8"	4-7/8"	8	7/16"	3/8"
4"	6-5/8"	3/8"	5-7/8"	8	7/16"	3/8"
6"	8-7/8"	3/8"	8-1/8"	12	7/16"	3/8"

¹ Listed thickness is for aluminum flanges

ANSI Flange Dimensions

150 lb. Standard

Nominal Pipe Size	Outside Diameter Flange	Flange Thickness	Drill Template		
			Number Holes	Diameter Bolts	Bolt Circle
1/2"	3-1/2"	7/16"	4	1/2"	2-3/8"
3/4"	3-7/8"	1/2"	4	1/2"	2-3/4"
1"	4-1/4"	9/16"	4	1/2"	3-1/8"
1-1/4"	4-5/8"	5/8"	4	1/2"	3-1/2"
1-1/2"	5"	11/16"	4	1/2"	3-7/8"
2"	6"	3/4"	4	5/8"	4-3/4"
2-1/2"	7"	7/8"	4	5/8"	5-1/2"
3"	7-1/2"	15/16"	4	5/8"	6"
3-1/2"	8-1/2"	15/16"	8	5/8"	7"
4"	9"	15/16"	8	5/8"	7-1/2"
5"	10"	15/16"	8	3/4"	8-1/2"
6"	11"	1"	8	3/4"	9-1/2"
8"	13-1/2"	1-1/8"	8	3/4"	11-3/4"
10"	16"	1-3/16"	12	3/4"	14-1/4"
12"	19"	1-1/4"	12	3/4"	17"

300 lb. Standard

Nominal Pipe Size	Outside Diameter Flange	Flange Thickness	Drill Template		
			Number Holes	Diameter Bolts	Bolt Circle
1/2"	3-3/4"	9/16"	4	1/2"	2-5/8"
3/4"	4-5/8"	5/8"	4	5/8"	3-1/4"
1"	4-7/8"	11/16"	4	5/8"	3-1/2"
1-1/4"	5-1/4"	3/4"	4	5/8"	3-7/8"
1-1/2"	6-1/8"	13/16"	4	3/4"	4-1/2"
2"	6-1/2"	7/8"	8	5/8"	5"
2-1/2"	7-1/2"	1"	8	3/4"	5-7/8"
3"	8-1/4"	1-1/8"	8	3/4"	6-5/8"
3-1/2"	9"	1-3/16"	8	3/4"	7-1/4"
4"	10"	1-1/4"	8	3/4"	7-7/8"
5"	11"	1-3/8"	8	3/4"	9-1/4"
6"	12-1/2"	1-7/16"	12	3/4"	10-5/8"
8"	15"	1-5/8"	12	7/8"	13"
10"	17-1/2"	1-7/8"	16	1"	15-1/4"
12"	20-1/2"	2"	16	1-1/8"	17-3/4"

600 lb. Standard

Nominal Pipe Size	Outside Diameter Flange	Flange Thickness	Drill Template		
			Number Holes	Diameter Bolts	Bolt Circle
1/2"	3-3/4"	9/16"	4	5/8"	2-5/8"
3/4"	4-5/8"	5/8"	4	3/4"	3-1/4"
1"	4-7/8"	11/16"	4	3/4"	3-1/2"
1-1/4"	5-1/4"	13/16"	4	3/4"	3-7/8"
1-1/2"	6-1/8"	7/8"	4	7/8"	4-1/2"
2"	6-1/2"	1"	8	3/4"	5"
2-1/2"	7-1/2"	1-1/8"	8	7/8"	5-7/8"
3"	8-1/4"	1-1/4"	8	7/8"	6-5/8"
3-1/2"	9"	1-3/8"	8	1"	7-1/4"
4"	10-7/5"	1-1/2"	8	1"	8-1/2"
5"	13"	1-3/4"	8	1-1/8"	10-1/2"
6"	14"	1-7/8"	12	1-1/8"	11-1/2"
8"	16-1/2"	2-3/16"	12	1-1/4"	13-3/4"
10"	20"	2-1/2"	16	1-3/8"	17"
12"	22"	2-5/8"	20	1-3/8"	19-1/4"

900 lb. Standard

Nominal Pipe Size	Outside Diameter Flange	Flange Thickness	Drill Template		
			Number Holes	Diameter Bolts	Bolt Circle
1/2"	4-3/4"	7/8"	4	7/8"	3-1/4"
3/4"	5-1/8"	1"	4	7/8"	3-1/2"
1"	5-7/8"	1-1/8"	4	1"	4"
1-1/4"	6-1/4"	1-1/8"	4	1"	4-3/8"
1-1/2"	7"	1-1/4"	4	1-1/8"	4-7/8"
2"	8-1/2"	1-1/2"	8	1"	6-1/2"
2-1/2"	9-5/8"	1-5/8"	8	1-1/8"	7-1/2"
3"	9-1/2"	1-1/2"	8	1"	7-1/2"
3-1/2"	11-1/2"	1-3/4"	8	1-1/4"	9-1/4"
4"	13-3/4"	2"	8	1-3/8"	11"
6"	15"	2-3/16"	12	1-1/4"	12-1/2"
8"	18-1/2"	2-1/2"	12	1-1/2"	15-1/2"
10"	21-1/2"	2-3/4"	16	1-1/2"	18-1/2"
12"	24"	3-1/8"	20	1-1/2"	21"

Pressure Rating Chart

Spool or rotating assembly only - Pressure rating of final assembly may be derated due to end connections

Swivel Type	Material	1"	1-1/4"	1-1/2"	2"	2-1/2"	3"	4"	5"	6"	8"	10"	12"	14"	16"	18"	20"	24"	
O-Ring	Aluminum	150	150	150	150	150	150	150											
	Brass			300	300		300												
	Ductile Iron			600	600		600	600											
	Carbon Steel	1000	*	1000	1000	1000	1000	1000											
	Stainless Steel	1000	*	1000	1000	1000	1000												
V-Ring	Aluminum									150	150								
	Carbon Steel				1000	1000	1000	1000	1000	1000	1000	1000	1000	1000					
	Stainless Steel				1000	1000	1000	1000	1000	1000	1000	1000	1000	*					
Cap Seal	Carbon Steel													1000	800	1000	900	800	
	Stainless Steel													*	800	1000	*	*	
Split Flange	Aluminum				600		600	600											
	Carbon Steel				600		600	600											
	Stainless Steel				600		600	600											
High Capacity Split Flange	Carbon Steel				*		*	1000											
	Stainless Steel				*		*	1000											

* Contact Dixon for additional information

Dixon® swivels are recommended for use at the following maximum Non-Shock Cold Working Pressures (NSCWP) provided in **PSI** at ambient temperature **70°F (21°C)** for 1" – 24" sizes:



- When using flanged ends, the pressure rating will be reduced to coincide with that of the flange being used. Carbon steel and stainless steel 150# flanges are recommended for use at **275 PSI** maximum and 300# flanges at **740 PSI** at ambient temperature **70°F (21°C)**.
- TTMA flanges are recommended for use at **150 PSI** maximum at ambient temperature **70°F (21°C)**.
- Lubrication should be performed periodically, depending on service and operation conditions. Biannually is normally sufficient.
- All dimensions are approximate. Where critical, consult Dixon.

Limited Warranty

DIXON VALVE AND COUPLING COMPANY, LLC (herein called "Dixon") warrants the products described herein and manufactured by Dixon to be free from defects in material and workmanship for a period of one (1) year from date of shipment by Dixon under normal use and service. Its sole obligation under this warranty being limited to repairing or replacing, as hereinafter provided, at its option any product found to Dixon's satisfaction to be defective upon examination by it, provided that such product shall be returned for inspection to Dixon's factory within three (3) months after discovery of the defect. The repair or replacement of defective products will be made without charge for parts or labor. This warranty shall not apply to: (a) parts or products not manufactured by Dixon, the warranty of such items being limited to the actual warranty extended to Dixon by its supplier; (b) any product that has been subject to abuse, negligence, accident, or misapplication; (c) any product altered or repaired by others than Dixon; and (d) to normal maintenance services and the replacement of service items (such as washers, gaskets, and lubricants) made in connection with such services. To the extent permitted by law, this limited warranty shall extend only to the buyer and any other person reasonably expected to use or consume the goods who is injured in person by any breach of the warranty. No action may be brought against Dixon for an alleged breach of warranty unless such action is instituted within one (1) year from the date the cause of action accrues. This limited warranty shall be construed and enforced to the fullest extent allowable by applicable law.

Other than the obligation of Dixon set forth herein, Dixon disclaims all warranties, express or implied, including but not limited to any implied warranties of merchantability or fitness for a particular purpose, and any other obligation or liability. The foregoing constitutes Dixon's sole obligation with respect to damages, whether direct, incidental, or consequential, resulting from the use or performance of the product.

Some products and sizes may be discontinued when stock is depleted or may require a minimum quantity for ordering.

About This Brochure and Our Products

This brochure is intended as a product offering. It is not a user or technical manual. Information in this brochure is subject to change without notice. We may modify product design and specification without notice and without any obligation to modify or substitute products previously purchased. All users and distributors of products sold through this brochure are strongly encouraged to contact Dixon with questions on use, compatibilities, coupling procedures, and life of product. Our full-time engineering and test staff are always available to recommend uses and to assist distributors and users with questions.



Safety



Safety logos, which appear throughout our brochure, are used as a reminder that the user should carefully review for the appropriateness of the product for the media, application, and environment in which it will be used.

NOTE: Because of the health hazards associated with contamination and lead content in drinking water systems, Dixon couplings, unless otherwise specifically approved, are not recommended for potable water service and should not be used in applications where drinking water will contact the wetted surfaces of the coupling.

All Dixon products are shipped in cartons with the following warning:

"WARNING: This product contains lead, a chemical known to the State of California to cause cancer and birth defects or other reproductive harm."

Trademarks

Delrin® and Zytel® are registered trademarks of DuPont Nemours and Company.

Kalrez® is a registered trademark of DuPont Dow Elastomers.

All other trademarks appearing in the Dixon illustrated price list are the property of their respective owners.

Copyright

Copyright © 2024 by Dixon Valve and Coupling, LLC

All rights reserved. This book is copyrighted material. Use, reproduction or copying of it by anyone other than Dixon® is strictly forbidden without its express written consent.

NOTE: Reasonable care has been taken in preparing this brochure. Dixon Valve & Coupling Company, LLC reserves the right to make corrections.

